

Primary switch mode power supplies

Product group picture

3



Primary switch mode power supplies

Table of contents

Primary switch mode power supplies	
Table of contents	3/2
Overview	3/3
Approvals and marks	3/4
Selection table - Single-phase	3/5
Selection table - Three-phase, CP-ASI	3/6
CP-D range	3/7
Table of contents	3/8
Benefits and advantages	3/9
Ordering details	3/10
Technical data	3/11
Technical diagrams	3/15
Dimensional drawings	3/16
CP-E range	3/17
Table of contents	3/18
Benefits and advantages	3/19
Ordering details	3/20
Technical data	3/21
Technical diagrams, Wiring instructions	3/29
Technical diagrams, Dimensional drawings	3/30
CP-T range	3/31
Table of contents	3/32
Benefits and advantages	3/33
Ordering details	3/34
Technical data	3/35
Technical diagrams, Dimensional drawings	3/39
Technical diagrams	3/40
CP-S and CP-C	3/41
Table of contents	3/42
Benefits and advantages	3/43
Operating control	3/44
Ordering details	3/45
Technical data	3/46
Technical diagrams, Dimensional drawings	3/50
Redundancy units	3/51
Ordering details	3/51
Technical data	3/52
Dimensional drawings	3/56
CP-ASI range	3/57
Table of contents	3/58
Benefits and advantages	3/59
Ordering details	3/60
Technical data	3/61
Technical diagrams	3/63
Dimensional drawings	3/64
CP-B range	3/65
Table of contents	3/66
Benefits and advantages	3/67
Ordering details	3/68
Technical data	3/69
Technical data, Technical diagrams	3/70
Dimensional drawings	3/71
Electronic protection devices EPD24	3/73

Primary switch mode power supplies

Overview

Modern power supply units are a vital component in most areas of energy management and automation technology. ABB as your global partner in these areas pays the utmost attention to the resulting requirements. Innovation is the key to a substantial enlargement of our power supply product program:

CP-D

The CP-D range of power supply units in MDRC design (modular DIN rail components) fits into all domestic installation and distribution panels.

CP-E

The CP-E range offers enhanced functionality while the number of different types has been considerably reduced. Now all power supply units can be operated at an ambient temperature of up to +70 °C.

CP-T

The CP-T range of three-phase power supply units is ABB's youngest member of the power supply family.

CP-S

The CP-S range is ABB's standard range, a high-end power supply unit optimised for serial applications.

CP-C

The CP-C range's pluggable function modules adapt these power supply units exactly to your application's needs. Of course, all ABB power supply units feature primary switch mode technology – environmentally sound and cost-efficiency. This represents the highest level of innovative industrial electronics.

Application manual

For today's applications, e.g. in control engineering, it is essential to make the right decision regarding the selection and planning of the power supply unit. Incorrect dimensioning or incorrect connection of a power supply unit can seriously affect the safety and/or availability of the entire installation.

ABB's "Power Supply Units" application manual provides a general overview of switch mode power supply units, thus helping you to choose the ideal power supply unit and avoid problems during engineering and commissioning. The manual generally shows and explains the fundamental

characteristics of and the differences between power supply units, and provides a detailed introduction to the ABB product range on the basis of the selection criteria. Finally, it describes and explains application examples for engineering.

The manual is available in English and German.

English Version: 2CDC 114 048 M0203

German Version: 2CDC 114 048 M0103

Primary switch mode power supplies

Approvals and marks

		CP-D						
		CP-D 12/0.83	CP-D 12/2.1	CP-D 24/0.42	CP-D 24/1.3	CP-D 24/2.5	CP-D 24/4.2	CP-D RU
Approvals								
	UL 508, CAN/CSA C22.2 No.107.1	■ ¹⁾	■ ¹⁾	■ ¹⁾	■ ¹⁾	■ ¹⁾	■ ¹⁾	
	UL 1310, CAN/CSA C22.2 No.223 (Class 2 Power Supply)	■ ¹⁾	■ ¹⁾	■ ¹⁾	■ ¹⁾	■ ¹⁾		
	UL 60950, CAN/CSA C22.2 No.60950	■ ¹⁾	■ ¹⁾	■ ¹⁾	■ ¹⁾	■ ¹⁾	■ ¹⁾	
	GOST	■ ²⁾	■ ²⁾	■ ²⁾	■ ²⁾	■ ²⁾	■ ²⁾	
	CCC	■ ¹⁾	■ ¹⁾	■ ¹⁾	■ ¹⁾	■ ¹⁾	■ ¹⁾	
Marks								
	CE	■	■	■	■	■	■	■
	C-Tick	□	□	□	□	□	□	

		CP-E												CP-T									
		CP-E 5/3.0	CP-E 12/2.5	CP-E 12/10.0	CP-E 24/0.75	CP-E 24/1.25	CP-E 24/2.5	CP-E 24/5.0	CP-E 24/10.0	CP-E 24/20.0	CP-E 48/0.62	CP-E 48/1.25	CP-E 48/5.0	CP-E 48/10.0	CP-RUD	CP-T 24/5.0	CP-T 24/10.0	CP-T 24/20.0	CP-T 24/40.0	CP-T 48/5.0	CP-T 48/10.0	CP-T 48/20.0	
Approvals																							
	UL 508, CAN/CSA C22.2 No.107.1	■ ¹⁾	■ ¹⁾	■ ¹⁾	■ ¹⁾	■ ¹⁾	■ ¹⁾	■ ¹⁾	■ ¹⁾	■ ¹⁾	■ ¹⁾	■ ¹⁾	■ ¹⁾	■ ¹⁾		■ ¹⁾	■ ¹⁾	■ ¹⁾	■ ¹⁾	■ ¹⁾	■ ¹⁾	■ ¹⁾	■ ¹⁾
	UL 1310, CAN/CSA C22.2 No.223 (Class 2 Power Supply)	■	■		■	■	■				■	■									■	■	■
	ANSI/ISA-12.12 (Class I, Div. 2, hazardous locations) CAN/CSA C22.2 No. 213	■	■	■	■	■	■	■	■	■	■	■	■	■		■	■	■	■	■	■	■	■
	UL 60950, CAN/CSA C22.2 No.60950	■ ¹⁾	■ ¹⁾	■ ¹⁾	■ ¹⁾	■ ¹⁾	■ ¹⁾	■ ¹⁾	■ ¹⁾	■ ¹⁾	■ ¹⁾	■ ¹⁾	■ ¹⁾	■ ¹⁾		■ ¹⁾	■ ¹⁾	■ ¹⁾	■ ¹⁾	■ ¹⁾	■ ¹⁾	■ ¹⁾	■ ¹⁾
	GOST	■ ²⁾	■ ²⁾	■ ²⁾	■ ²⁾	■ ²⁾	■ ²⁾	■ ²⁾	■ ²⁾	■ ²⁾	■ ²⁾	■ ²⁾	■ ²⁾	■ ²⁾		■ ²⁾	■ ²⁾	■ ²⁾	■ ²⁾	■ ²⁾	■ ²⁾	■ ²⁾	■ ²⁾
	CCC	■ ¹⁾	■ ¹⁾	■ ¹⁾	■ ¹⁾	■ ¹⁾	■ ¹⁾	■ ¹⁾	■ ¹⁾	■ ¹⁾	■ ¹⁾	■ ¹⁾	■ ¹⁾	■ ¹⁾									
	GB4943, GB9254, GB17625.1															■	■	■	■	■	■	■	■
Marks																							
	CE	■	■	■	■	■	■	■	■	■	■	■	■	■	■	■	■	■	■	■	■	■	■
	C-Tick	■	■	■	■	■	■	■	■	■	■	■	■	■	■	□	□	□	□	□	□	□	□

		CP-S			CP-C				CP-A		CP-B			
		CP-S 24/5.0	CP-S 24/10.0	CP-S 24/20.0	CP-C 24/5.0	CP-C 24/10.0	CP-C 24/20.0	CP-C MM	CP-A RU	CP-A CM	CP-B 24/3.0	CP-B 24/10.0	CP-B 24/20.0	CP-B EXT.2
Approvals														
	UL 508, CAN/CSA C22.2 No.107.1	■ ¹⁾	■ ¹⁾	■ ¹⁾	■ ¹⁾	■ ¹⁾	■ ¹⁾				■	■	■	■
	UL 1604 (Class I, Div. 2, hazardous locations), CAN/CSA C22.2 No.213	■ ¹⁾	■ ¹⁾	■ ¹⁾	■ ¹⁾	■ ¹⁾	■ ¹⁾							
	UL 60950, CAN/CSA C22.2 No.60950	■ ¹⁾	■ ¹⁾	■ ¹⁾	■ ¹⁾	■ ¹⁾	■ ¹⁾		■ ¹⁾	■ ¹⁾				
	GOST	■ ²⁾	■ ²⁾	■ ²⁾	■ ²⁾	■ ²⁾	■ ²⁾	■ ²⁾	■ ²⁾	■ ²⁾	■ ²⁾	■ ²⁾	■ ²⁾	■ ²⁾
	CB scheme	■	■	■	■	■	■		■	■				
Marks														
	CE	■	■	■	■	■	■	■	■	■	■	■	■	■
	C-Tick	■	■	■	■	■	■	■	■	□				

¹⁾ Approvals refer to the rated input voltage U_n.
²⁾ May have been replaced by EAC during the availability of this catalog edition.

Primary switch mode power supplies

Selection table - Single-phase

3

		Single phase																									
		CP-D						CP-E												CP-S			CP-C				
		1SVR 427 041 R1000	1SVR 427 043 R1200	1SVR 427 041 R0000	1SVR 427 043 R0100	1SVR 427 044 R0200	1SVR 427 045 R0400	1SVR 427 033 R3000	1SVR 427 032 R1000	1SVR 427 035 R1000	1SVR 427 030 R0000	1SVR 427 031 R0000	1SVR 427 032 R0000	1SVR 427 034 R0000	1SVR 427 035 R0000	1SVR 427 036 R0000	1SVR 427 030 R2000	1SVR 427 031 R2000	1SVR 427 034 R0000	1SVR 427 035 R2000	1SVR 427 014 R0000	1SVR 427 015 R0100	1SVR 427 016 R0100	1SVR 427 024 R0000	1SVR 427 025 R0000	1SVR 427 026 R0000	
Rated output voltage	5 VDC							■																			
	12 VDC	■	■						■	■																	
	24 VDC			■	■	■	■				■	■	■	■	■						■	■	■	■	■	■	
	48 VDC																■	■	■	■							
Rated output current	0.42 A			■																							
	0.625 A																										
	0.75 A									■																	
	0.83 A	■																									
	1.25 A											■															
	1.3 A																										
	2.1 A		■																								
	2.5 A									■				■													
	3 A								■																		
	4.2 A																										
	5 A																					■			■		
	10 A														■								■			■	
	20 A															■								■		■	
	Rated output power	10 W	■		■																						
15 W									■																		
18 W																											
30 W			■		■					■																	
60 W						■																					
100 W							■																				
120 W											■																
240 W																											
480 W																											
Rated input voltage	100 - 240 V AC	■	■	■	■	■	■	■	■	■	■	■	■	■	■	■	■	■	■	■	■	■	■	■	■	■	
	115/230 V AC auto select																										
	115 - 230 V AC																										
	110 - 240 V AC																										
	110 - 120 V AC																										
DC input voltage range	220 - 240 V AC																										
	120 - 370 V DC	■	■	■	■	■	■	■			■																
	90 - 375 V DC																										
	210 - 370 V DC																										
Features	100 - 350 V DC																										
	220 - 350 V DC																										
	Power reserve design																										
	Adjustable output voltage		■		■	■	■		■	■	■	■	■	■	■	■	■	■	■	■	■	■	■	■	■	■	
	Integrated input fuse	■	■	■	■	■	■	■	■	■	■	■	■	■	■	■	■	■	■	■	■	■	■	■	■	■	
	Short circuit stable	■	■	■	■	■	■	■	■	■	■	■	■	■	■	■	■	■	■	■	■	■	■	■	■	■	
	Fold forward behavior (U/I)	■	■	■	■	■	■		■	■																	
	Fold back behavior (hiccup)							■			■																
	Power factor correction																										
	Ambient temp. rating -25°C (-40°C) to 70°C	■	■	■	■	■	■	■	■	■	■	■	■	■	■	■	■	■	■	■	■	■	■	■	■	■	
Parallel connection							■	■	3	■	■	■	3	3	3	■	■	3	3	■	5	5	5	5	5		
Serial connection	■	■	■	■	■	■	■	■	2	■	■	■	2	2	2	■	■	2	2	■	■	■	■	■	■		

Primary switch mode power supplies

Selection table - Three-phase, CP-ASI

		Order number												
		1SVR 427 054 R0000	1SVR 427 055 R0000	1SVR 427 056 R0000	1SVR 427 057 R0000	1SVR 427 054 R2000	1SVR 427 055 R2000	1SVR 427 056 R2000	1SVR 427 090 R0280	1SVR 427 090 R0400	1SVR 427 095 R0400	1SVR 427 090 R0800		
		Three phase							AS-Interface					
		CP-T							CP-ASI					
Rated output voltage	24 V DC	■	■	■	■									
	30.5 V DC								■	■	■	■		
	48 V DC					■	■	■						
Rated output current	2.8 A								■					
	3 A									■	■			
	5 A	■				■								
	8 A												■	
	10 A		■				■							
	20 A			■				■						
	40 A				■									
Rated output power	85 W								■					
	120 W	■												
	122 W									■	■			
	240 W		■			■								
	244 W												■	
	480 W			■			■							
960 W				■			■							
Rated input voltage	85-132 V AC, 184-264 V AC								■	■		■		
	3 x 400 - 800 V AC	■	■	■	■	■	■	■						
DC input voltage range	18-32.4 V DC											■		
	480 - 820 V DC	■	■	■	■	■	■	■						
Features	Adjustable output voltage	■	■	■	■	■	■	■						
	Integrated input fuse	■	■	■	■	■	■	■						
	Short circuit stable	■	■	■	■	■	■	■						
	Fold forward behavior (U/I)	■	■	■	■	■	■	■						
	Fold back behavior (hiccup)	■	■	■	■	■	■	■						
	Power factor correction													
	Ambient temp. rating -25°C (-40°C) to 70°C	■	■	■	■	■	■	■						
	Serial connection		2	2	2	2	2	2						
	Suited for AS-Interfaces								■	■	■	■		

CP-D range

Product group picture

3



CP-D range

Table of contents

CP-D range	
Product group picture	3/7
Table of contents	3/8
Benefits and advantages	3/9
Ordering details	3/10
Technical data	3/11
Technical diagrams	3/15
Dimensional drawings	3/16

CP-D range

Benefits and advantages

Characteristics

- Output voltages 12 V, 24 V DC
 - Adjustable output voltages (devices > 10 W)
 - Output currents 0.42 A / 0.83 A / 1.3 A / 2.1 A / 2.5 A / 4.2 A
 - Power range 10 W, 30 W, 60 W, 100 W
 - Wide range input 100-240 V AC (90-264 V AC, 120-375 V DC)
 - High efficiency of up to 89 %
 - Low power dissipation and low heating
 - Free convection cooling (no forced cooling with ventilators)
 - Ambient temperature range during operation -40 °C...+70 °C
 - Open-circuit, overload and short-circuit stable
 - Integrated input fuse
 - U/I characteristic (fold-forward behaviour at overload – no switch-off)
 - LEDs for status indication
 - Light-grey housing in RAL 7035
- Approvals / Marks
(depending on device, partly pending):



Benefits

Width and structural form ①

With their width between 18 to 90 mm only, the CP-D range switch mode power supplies are ideally suited for installation in distribution panels.

Wide range input ②

Optimised for world-wide applications: The CP-D power supplies can be supplied with 90-264 V AC or 120-375 V DC.

Adjustable output voltage ③

The CP-D range types > 10 W feature a continuously adjustable output voltage. Thus, they can be optimally adapted to the application, e.g. compensating the voltage drop caused by a long line length.

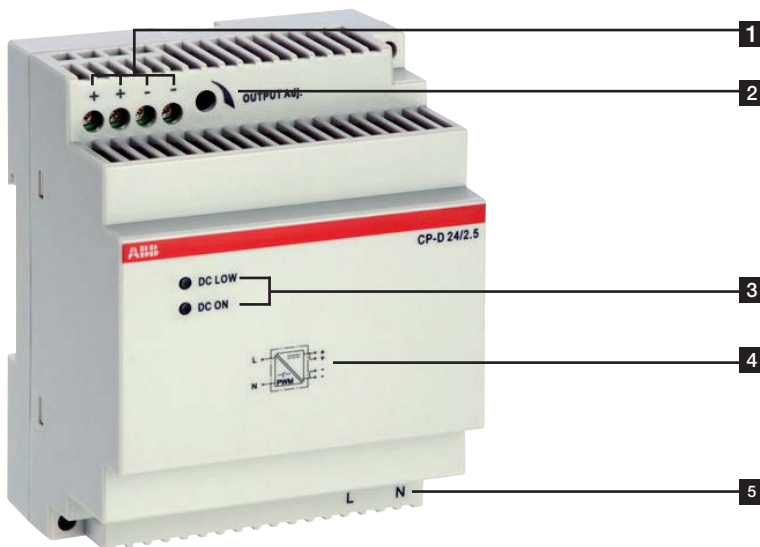
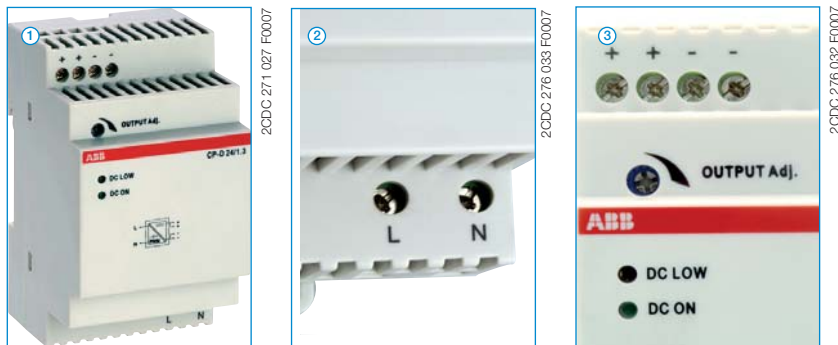

- 1** OUTPUT ++/--: terminals - output
- 2** INPUT L, N: terminals - input
- 3** Indication of operational states
DC ON: green LED - output voltage applied
DC LOW: red LED - output voltage too low
- 4** Circuit diagram
- 5** OUTPUT Adjust: potentiometer - adjustment of output voltage

CP-D range

Ordering details



2CDC 271 024 F0007

CP-D 12/0.83, CP-D 24/0.42



2CDC 271 025 F0007

CP-D 12/2.1, CP-D 24/1.3



2CDC 271 028 F0007

CP-D 24/2.5

Description

The CP-D range of modular power supply units in MDRC design (modular DIN rail components) is ideally suited for installation in distribution panels. This range offers devices with output voltages of 12 V DC and 24 V DC at output currents of 0.42 A to 4.2 A. Thanks to a high thermal efficiency corresponding to low power and heat dissipation, the devices can be operated without forced cooling. All devices feature the U/I output characteristic (fold forward behaviour). All power supply units in the CP-D range are approved according to all relevant international standards.

Ordering details

Input voltage range	Rated output voltage / current	Type	Order code	Price 1 pce	Weight (1 pce) kg (lb)
90-264 V AC/ 120-375 V DC	12 V DC / 0.83 A	CP-D 12/0.83	1SVR427041R1000		0.06 (0.13)
90-264 V AC/ 120-375 V DC	12 V DC / 2.1 A	CP-D 12/2.1	1SVR427043R1200		0.19 (0.41)
90-264 V AC/ 120-375 V DC	24 V DC / 0.42 A	CP-D 24/0.42	1SVR427041R0000		0.06 (0.13)
90-264 V AC/ 120-375 V DC	24 V DC / 1.3 A	CP-D 24/1.3	1SVR427043R0100		0.19 (0.41)
90-264 V AC/ 120-375 V DC	24 V DC / 2.5 A	CP-D 24/2.5	1SVR427044R0200		0.25 (0.56)
90-264 V AC/ 120-375 V DC	24 V DC / 4.2 A	CP-D 24/4.2	1SVR427045R0400		0.32 (0.71)

CP-D range

Technical data

Data at $T_a = 25\text{ °C}$, $U_{in} = 230\text{ V AC}$ and rated values, unless otherwise indicated

Type	CP-D 12/0.83	CP-D 12/2.1
Input circuit - supply circuit		
	L, N	
Rated input voltage U_n	100-240 V AC	
Input voltage range	90-264 V AC / 120-375 V DC	
Frequency range AC	47-63 Hz	
Typical input current / typical power consumption	at 110 V AC: 200 mA / 12.68 W at 230 V AC: 128.3 mA / 13.01 W	502 mA / 31.14 W 277 mA / 31.2 W
Inrush current limiting	at 230 V AC: 30 A (max. 3 ms)	50 A (max. 3 ms)
Power failure buffering time	min. 30 ms	
Internal input fuse	1 A slow-acting / 250 V AC	2 A slow-acting / 250 V AC
Power factor correction (PFC)	no	
Indication of operational states		
Output voltage	DC ON: green LED DC LOW: red LED	: output voltage applied : output voltage too low
Output circuit		
	+, -	++, --
Rated output voltage	12 V DC	
Tolerance of the output voltage	±1 %	
Adjustment range of the output voltage	-	12-14 V DC
Rated output power	10 W	30 W
Rated output current I_r	$T_a \leq 60\text{ °C}$: 0.83 A	2.1 A
Derating of the output current	$60\text{ °C} < T_a \leq 70\text{ °C}$: 2.5 %/°C	
Maximum deviation with change of output voltage within the input voltage range	load change statical	max. 1 %
Control time	< 1 ms	
Starting time after applying the supply voltage	at I_r	1000 ms
Rise time	at rated load	typ. 1 ms
Residual ripple and switching peaks	BW = 20 MHz	50 mV
Parallel connection	yes, using CP-D RU	
Series connection	yes, to increase voltage	
Resistance to reverse feed	18 V / 1 s	
Output circuit - No-load, overload and short-circuit behaviour		
Characteristic curve of output	U/I characteristic curve	
Short-circuit protection	continuous short-circuit stability	
Short-circuit behaviour	continuation with output power limiting	
Current limiting at short circuit	typ. 1.4 A	typ. 5.9 A
Overload protection	output power limiting	
Overvoltage protection	15-16.5 V DC	
No-load protection	continuous no-load stability	
Starting of capacitive loads	unlimited	
General data		
Efficiency	typ. 78 %	typ. 82 %
Duty time	100 %	
Dimensions (W x H x D)	18 x 91 x 57.5 mm (0.71 x 3.58 x 2.26 in)	53 x 91 x 57.5 mm (2.09 x 3.58 x 2.26 in)
Weight	0.066 kg (0.13 lb)	0.196 kg (0.41 lb)
Material of housing	plastic	
Mounting	DIN rail (IEC/EN 60715), snap-on mounting without any tool	
Mounting position	horizontal	
Minimum distance to other units	horizontal / vertical	25 mm / 25 mm (0.98 in / 0.98 in)
Degree of protection	housing / terminals	IP20 / IP20
Protection class	II	

CP-D range

Technical data

Data at $T_a = 25\text{ °C}$, $U_n = 230\text{ V AC}$ and rated values, unless otherwise indicated

Type		CP-D 12/0.83	CP-D 12/2.1
Electrical connection - Input circuit / Output circuit			
Wire size	fine-strand with wire end ferrule	0.2-1.5 mm ² (24-16 AWG)	0.2-2.5 mm ² (24-14 AWG)
	rigid	0.2-2.5 mm ² (26-12 AWG)	0.2-2.5 mm ² (24-12 AWG)
Stripping length		4-5 mm (0.16-0.2 in)	7 mm (0.28 in)
Tightening torque		0.6 Nm (5 lb.in)	0.7 Nm (6 lb.in)
Environmental data			
Ambient temperature range	operation	-40...+70 °C	
	rated load	-40...+60 °C	
	storage	-40...+85 °C	
Damp heat (cyclic) (IEC/EN 60068-2-30)		4 x 24 cycles, 40 °C, 95 % RH	
Vibration (sinusoidal) (IEC/EN 60068-2-6)		50 m/s ² , 10 Hz - 2 kHz	
Shock (half-sine) (IEC/EN 60068-2-27)		40 m/s ² , 22 ms	
Isolation data			
Rated insulation voltage U_i	input circuit / output circuit	3 kV AC	
Pollution degree		2	
Overvoltage category (UL/IEC/EN 60950-1)		II	
Standards			
Product standard		EN 61204	
Low Voltage Directive		2006/95/EC	
EMC Directive		2004/108/EC	
Electrical safety		UL 508, UL 60950-1, EN 60950-1	
Protective low voltage		SELV (EN 60950-1)	
Electromagnetic compatibility			
Interference immunity to		EN 61000-6-2	
electrostatic discharge	IEC/EN 61000-4-2	Level 4 (4 kV / 8 kV)	Level 4 (4 kV / 15 kV)
radiated, radio-frequency, electromagnetic field	IEC/EN 61000-4-3	Level 3 (10 V/m)	
electrical fast transient/burst	IEC/EN 61000-4-4	Level 4 (4 kV)	
surge	IEC/EN 61000-4-5	Level 3 (2 kV L-L)	
conducted disturbances, induced by radio-frequency fields	IEC/EN 61000-4-6	Level 3 (10 V)	
Interference emission		EN 61000-6-3	
high-frequency radiated	IEC/CISPR 22, EN 55022	Class B	
high-frequency conducted	IEC/CISPR 22, EN 55022	Class B	

„Approvals and marks“ on page 3/4.

CP-D range

Technical data

Data at $T_a = 25\text{ }^\circ\text{C}$, $U_{in} = 230\text{ V AC}$ and rated values, unless otherwise indicated

Type	CP-D 24/0.42	CP-D 24/1.3	CP-D 24/2.5	CP-D 24/4.2	
Input circuit - supply circuit					
	L, N				
Rated input voltage U_{in}	100-240 V AC				
Input voltage range	90-264 V AC / 120-375 V DC				
Frequency range AC	47-63 Hz				
Typical input current / typical power consumption	at 110 V AC	184 mA / 11.62 W	600 mA / 37.92 W	1120 mA / 69.3 W	1800 mA / 117.3 W
	at 230 V AC	120.6 mA / 12 W	344 mA / 38.16 W	660 mA / 70.1 W	900 mA / 114.4 W
Inrush current limiting	at 230 V AC		30 A (max. 3 ms)	50 A (max. 3 ms)	60 A (max. 3 ms)
Power failure buffering time			min. 30 ms	min. 60 ms	
Internal input fuse	1 A slow-acting / 250 V AC		2 A slow-acting / 250 V AC		3.15 A slow-acting / 250 V AC
Power factor correction (PFC)	no				
Indication of operational states					
Output voltage	DC ON: green LED	[]: output voltage applied			
	DC LOW: red LED	[]: output voltage too low			
Output circuit					
	+, -		++, --		
Rated output voltage	24 V DC				
Tolerance of the output voltage	$\pm 1\%$				
Adjustment range of the output voltage	-		24-28 V DC		
Rated output power	10 W	30 W	60 W	100 W	
Rated output current I_o	$T_a \leq 60\text{ }^\circ\text{C}$: 0.42 A	$T_a \leq 60\text{ }^\circ\text{C}$: 1.3 A	$T_a \leq 55\text{ }^\circ\text{C}$: 2.5 A	$T_a \leq 60\text{ }^\circ\text{C}$: 4.2 A	
Derating of the output current	$60\text{ }^\circ\text{C} < T_a \leq 70\text{ }^\circ\text{C}$: 2.5 %/ $^\circ\text{C}$	$60\text{ }^\circ\text{C} < T_a \leq 70\text{ }^\circ\text{C}$: 2.5 %/ $^\circ\text{C}$	$55\text{ }^\circ\text{C} < T_a \leq 70\text{ }^\circ\text{C}$: 2.5 %/ $^\circ\text{C}$	$60\text{ }^\circ\text{C} < T_a \leq 70\text{ }^\circ\text{C}$: 2.5 %/ $^\circ\text{C}$	
Maximum deviation with load change statical change of output voltage within the input voltage range	max. 1 %				
Control time	< 1 ms				
Starting time after applying the supply voltage	at I_o 1000 ms				
Rise time	at rated load typ. 1 ms				
Residual ripple and switching peaks	BW = 20 MHz 50 mV				
Parallel connection	yes, using CP-D RU				
Series connection	yes, to increase voltage				
Resistance to reverse feed	35 V / 1 s				
Output circuit - No-load, overload and short-circuit behaviour					
Characteristic curve of output	U/I characteristic curve				
Short-circuit protection	continuous short-circuit stability				
Short-circuit behaviour	continuation with output power limiting				
Current limiting at short circuit	typ. 0.78 A	typ. 4.2 A	typ. 6.05 A	typ. 11.5 A	
Overload protection	output power limiting				
Overvoltage protection	30-33 V DC				
No-load protection	continuous no-load stability				
Starting of capacitive loads	unlimited				
General data					
Efficiency	typ. 80 %	typ. 83 %	typ. 86 %	typ. 89 %	
Duty time	100 %				
Dimensions (W x H x D)	18 x 91 x 57.5 mm (0.71 x 3.58 x 2.26 in)	53 x 91 x 57.5 mm (2.09 x 3.58 x 2.26 in)	71 x 91 x 57.5 mm (2.80 x 3.58 x 2.26 in)	89.9 x 91 x 57.5 mm (3.54 x 3.58 x 2.26 in)	
Weight	0.066 kg (0.13 lb)	0.196 kg (0.41 lb)	0.252 kg (0.55 lb)	0.386 kg / (0.72 lb)	
Material of housing	plastic				
Mounting	DIN rail (IEC/EN 60715), snap-on mounting without any tool				
Mounting position	horizontal				
Minimum distance to other units	horizontal / vertical		25 mm / 25 mm (0.98 in / 0.98 in)		
Degree of protection	housing / terminals		IP20 / IP20		
Protection class	II				

CP-D range

Technical data

Data at $T_a = 25\text{ °C}$, $U_n = 230\text{ V AC}$ and rated values, unless otherwise indicated

Type		CP-D 24/0.42	CP-D 24/1.3	CP-D 24/2.5	CP-D 24/4.2
Electrical connection - Input circuit / Output circuit					
Wire size	fine-strand with wire end ferrule	0.2-1.5 mm ² (24-16 AWG)	0.2-2.5 mm ² (24-14 AWG)		
	rigid	0.2-2.5 mm ² (26-12 AWG)	0.2-2.5 mm ² (24-12 AWG)		
Stripping length		4-5 mm (0.16-0.2 in)		7 mm (0.28 in)	
Tightening torque		0.6 Nm (5 lb.in)		0.7 Nm (6 lb.in)	
Environmental data					
Ambient temperature range	operation	-40...+70 °C			
	rated load	-40...+60 °C		-40...+55 °C	-40...+60 °C
	storage	-40...+85 °C			
Damp heat (cyclic) (IEC/EN 60068-2-30)		4 x 24 cycles, 40 °C, 95 % RH			
Vibration (sinusoidal) (IEC/EN 60068-2-6)		50 m/s ² , 10 Hz - 2 kHz			
Shock (half-sine) (IEC/EN 60068-2-27)		40 m/s ² , 22 ms			
Isolation data					
Rated insulation voltage U_i	input circuit / output circuit	3 kV AC		4 kV AC	3 kV AC
Pollution degree		2			
Overvoltage category (UL/IEC/EN 60950-1)		II			
Standards					
Product standard		EN 61204			
Low Voltage Directive		2006/95/EC			
EMC Directive		2004/108/EC			
Electrical safety		UL 508, UL 60950-1, EN 60950-1			
Protective low voltage		SELV (EN 60950-1)			
Electromagnetic compatibility					
Interference immunity to		EN 61000-6-2			
electrostatic discharge	IEC/EN 61000-4-2	Level 4 (4 kV / 8 kV)	Level 4 (4 kV / 15 kV)	Level 4 (4 kV / 8 kV)	
radiated, radio-frequency, electromagnetic field	IEC/EN 61000-4-3	Level 3 (10 V/m)			
electrical fast transient/burst	IEC/EN 61000-4-4	Level 4 (4 kV)			
surge	IEC/EN 61000-4-5	Level 3 (2 kV L-L)			
conducted disturbances, induced by radio-frequency fields	IEC/EN 61000-4-6	Level 3 (10 V)			
Interference emission		EN 61000-6-3			
high-frequency radiated	IEC/CISPR 22, EN 55022	Class B			
high-frequency conducted	IEC/CISPR 22, EN 55022	Class B			

„Approvals and marks“ on page 3/4.

CP-D range

Technical diagrams

3

Characteristic curve of output at $T_a = 25\text{ }^\circ\text{C}$

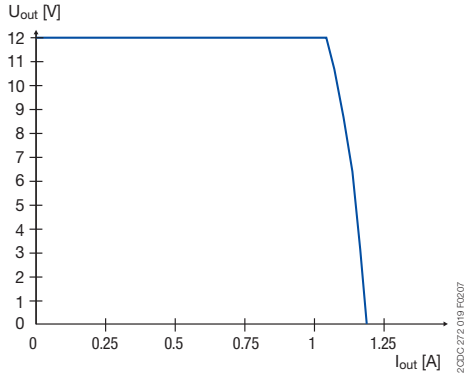

CP-D 12/0.83

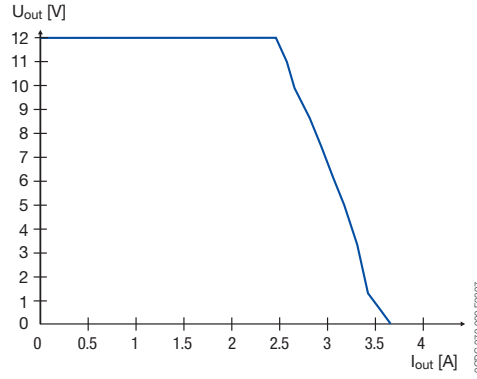

CP-D 12/2.1

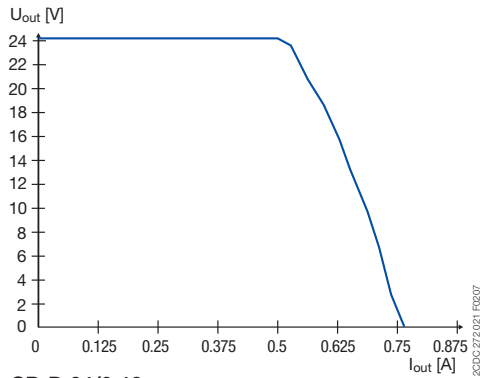

CP-D 24/0.42

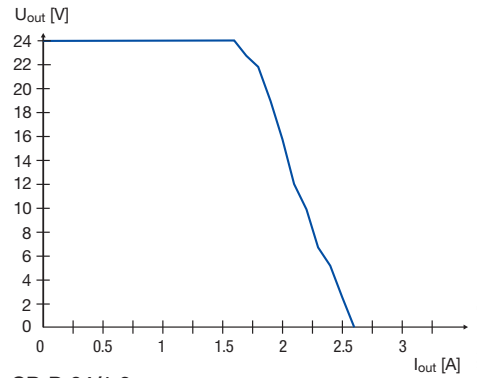

CP-D 24/1.3

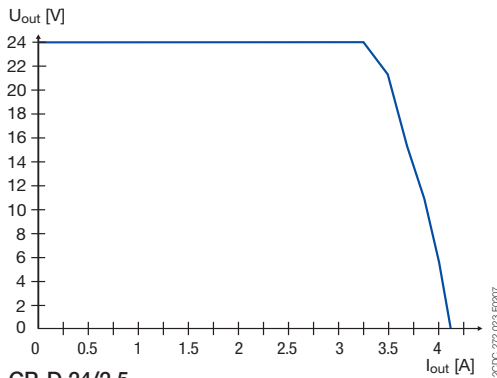

CP-D 24/2.5

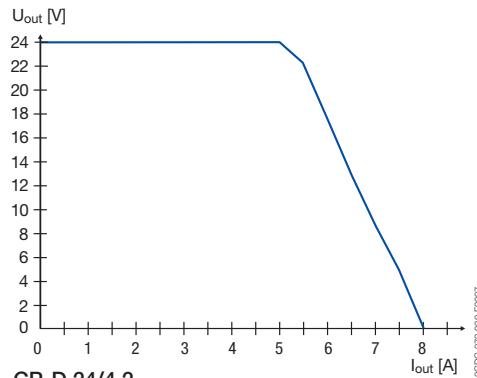

CP-D 24/4.2

Characteristic curve of temperature at rated output voltage

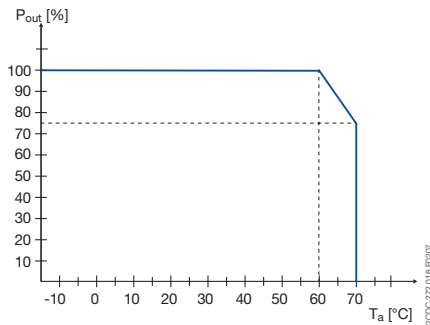

CP-D except CP-D 24/2.5

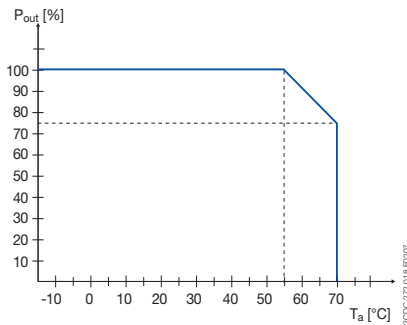

CP-D 24/2.5

CP-D range

Dimensional drawings

Dimensional drawings

dimensions in mm

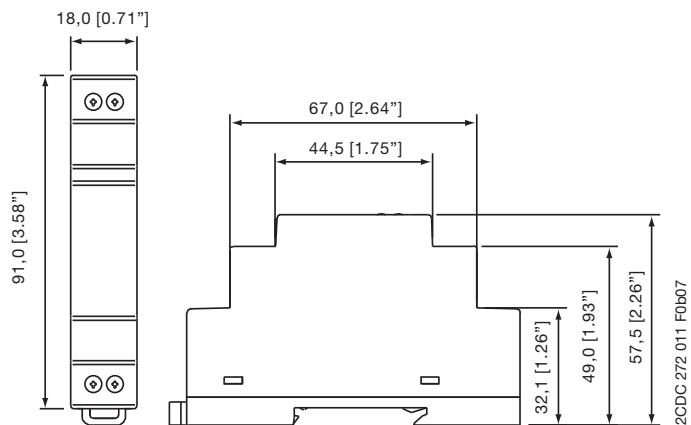

CP-D 12/0.83, CP-D 24/0.42

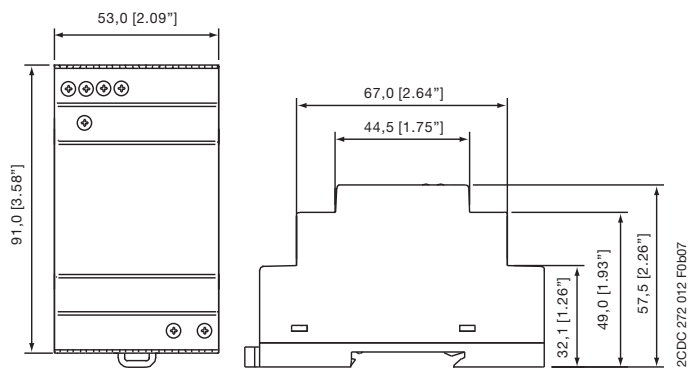

CP-D 12/2.1, CP-D 24/1.3

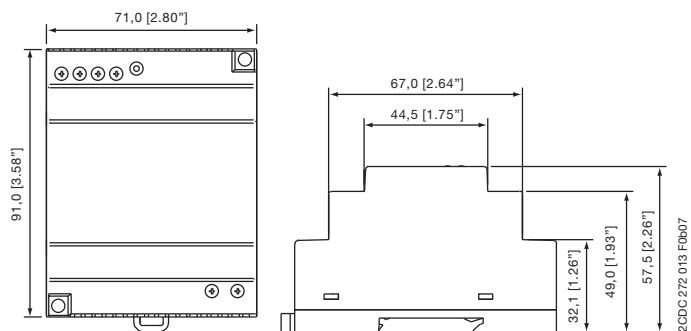

CP-D 24/2.5

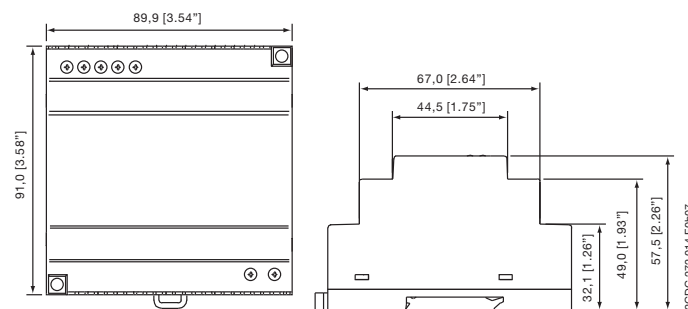

CP-D 24/4.2

CP-E range Product group picture

3



CP-E range

Table of contents

CP-E range	
Product group picture	3/17
Table of contents	3/18
Benefits and advantages	3/19
Ordering details	3/20
Technical data	3/21
Technical diagrams, Wiring instructions	3/29
Technical diagrams, Dimensional drawings	3/30

CP-E range

Benefits and advantages

3

Characteristics

- Output voltages 5 V, 12 V, 24 V, 48 V DC
- Adjustable output voltages
- Output currents 0.625 A / 0.75 A / 1.25 A / 2.5 A / 3 A / 5 A / 10 A / 20 A
- Power range 15 W, 18 W, 30 W, 60 W, 120 W, 240 W, 480 W
- High efficiency of up to 90 %
- Low power dissipation and low heating
- Free convection cooling (no forced cooling with ventilators)
- Ambient temperature range during operation -40...+70 °C
- Open-circuit, overload and short-circuit stable
- Integrated input fuse
- U/I characteristic curve on devices > 18 W (fold-forward behaviour at overload – no switch-off)
- Redundancy units offering true redundancy
- LED(s) for status indication
- Signalling output/contact for output voltage OK
Transistor on 24 V devices > 18 W and < 120 W
Solid-state on 24 V devices ≥ 120 W
- Approvals / Marks
(depending on device, partly pending):



Benefits

Signalling output/contact ①

The CP-E range 24 V devices > 18 W offer an output/contact for monitoring of the output voltage and remote diagnosis.

Wide range input ②

Optimised for world-wide applications: The CP-E power supplies can be supplied within a wide range of AC or DC voltage.

Adjustable output voltage ③

The CP-E range types feature a continuously adjustable output voltage. Thus, they can be optimally adapted to the application, e.g. compensating the voltage drop caused by a long line length.

Redundancy units ④

For decoupling of parallelized power supply units ≤ 40 V. Thus, true redundancy can be achieved.
Further information about redundancy unit on page 51.



2CDC 276 008 F0006



2CDC 276 008 F0006



2CDC 276 008 F0006



2CDC 271 006 F0003



- 1** INPUT L, N, PE: terminals - input
- 2** Circuit diagram
- 3** single/parallel: sliding switch - adjustment of single or parallel operation
- 4** Indication of operational states
DC ON: green LED - green LED - output voltage OK
DC LOW: red LED - output voltage too low
- 5** OUTPUT L+, L+, L-, L-: terminals - output
- 6** OUTPUT Adjust: potentiometer - adjustment of output voltage

CP-E range

Ordering details

Description

This range offers types with output voltages from 5 V DC to 48 V DC at output currents of 0.625 A to 20 A. The high thermal efficiency of up to 90 %, corresponding to very low power and heat dissipation, allows operation without forced cooling. The functionality has been enhanced while the number of different types has been considerably reduced.

Of course all power supplies of the CP-E range are approved in accordance with all relevant international standards.

Ordering details - CP-E < 100 W

Input voltage range	Rated output voltage / current	Type	Order code	Price 1 pce	Weight (1 pce) kg (lb)
90-264 V AC / 120-375 V DC	5 V DC / 3 A	CP-E 5/3.0	1SVR427033R3000		0.15 (0.33)
85-264 V AC / 90-375 V DC	12 V DC / 2.5 A	CP-E 12/2.5	1SVR427032R1000		0.29 (0.64)
90-132 V AC, 180-264 V AC / 210-375 V DC	12 V DC / 10 A	CP-E 12/10.0	1SVR427035R1000		1.00 (2.20)
90-264 V AC / 120-375 V DC	24 V DC / 0.75 A	CP-E 24/0.75	1SVR427030R0000		0.15 (0.33)
85-264 V AC / 90-375 V DC	24 V DC / 1.25 A	CP-E 24/1.25	1SVR427031R0000		0.29 (0.64)
85-264 V AC / 90-375 V DC	24 V DC / 2.5 A	CP-E 24/2.5	1SVR427032R0000		0.36 (0.79)



2C0C 271 017 F0008

CP-E 24/0.75



2C0C 271 013 F0008

CP-E 12/2.5



2C0C 271 028 F0008

CP-E 48/5.0





Ordering details - CP-E ≥ 120 W

Input voltage range	Rated output voltage / current	Type	Order code	Price 1 pce	Weight (1 pce) kg (lb)
90-132 V AC, 180-264 V AC / 210-375 V DC	24 V DC / 5 A	CP-E 24/5.0	1SVR427034R0000		1.00 (2.20)
90-132 V AC, 180-264 V AC / 210-375 V DC	24 V DC / 10 A	CP-E 24/10.0	1SVR427035R0000		1.36 (3.01)
90-264 V AC / 120-375 V DC	24 V DC / 20 A	CP-E 24/20.0	1SVR427036R0000		1.90 (4.18)
85-264 V AC / 90-375 V DC	48 V DC / 0.625 A	CP-E 48/0.62	1SVR427030R2000		0.29 (0.64)
85-264 V AC / 90-375 V DC	48 V DC / 1.25 A	CP-E 48/1.25	1SVR427031R2000		0.36 (0.79)
90-132 V AC, 180-264 V AC / 210-375 V DC	48 V DC / 5 A	CP-E 48/5.0	1SVR427034R2000		1.36 (3.01)
90-264 V AC / 120-375 V DC	48 V DC / 10 A	CP-E 48/10.0	1SVR427035R2000		1.90 (4.19)

CP-E range

Technical data

Data at $T_a = 25\text{ °C}$, $U_{in} = 230\text{ V AC}$ and rated values, unless otherwise indicated

Type	CP-E 5/3.0	CP-E 12/2.5	CP-E 12/10.0
Input circuit			
Rated input voltage U_{in}	100-240 V AC	L, N	
Input voltage range	90-264 V AC / 120-375 V DC	85-264 V AC / 90-375 V DC	115 / 230 V AC auto select 90-132 V AC, 180-264 V AC / 210-375 V DC
Frequency range AC	47-63 Hz		
Typical input current	at 115 V AC at 230 V AC	335 mA 210 mA	560 mA 330 mA 2.2 A 0.83 A
Typical power consumption		19.8 W	35.9 W 143 W
Inrush current limiting	at 115 V AC at 230 V AC	10 A (max. 3 ms) 18 A (max. 3 ms)	20 A (max. 3 ms) 40 A (max. 3 ms) 24 A (max. 5 ms) 48 A (max. 5 ms)
Discharge current	input / output input / PE	0.25 mA 3.5 mA	
Power failure buffering time	at 115 V AC at 230 V AC	min. 20 ms min. 75 ms	min. 20 ms min. 30 ms min. 25 ms min. 30 ms
Internal input fuse		2 A slow-acting / 250 V AC	3.15 A slow-acting / 250 V AC
Power factor correction (PFC)		no	yes, passive, 0.7
Indication of operational states			
Output voltage	green LED red LED	OK:  L: output voltage OK LOW:  L: output voltage too low	OUTPUT OK:  L: output voltage OK - OUTPUT LOW:  L: output voltage too low
Output circuit			
Rated output voltage		L+, L-	L+, L+, L-, L-
Rated output voltage		5 V DC	12 V DC
Tolerance of the output voltage		0...+1 %	
Adjustment range of the output voltage		4.5-5.75 V DC	12-14 V DC 11.4-14.5 V DC
Rated output power		15 W	30 W 120 W
Rated output current I_L	$T_a \leq 60\text{ °C}$	3.0 A	2.5 A 10 A
Derating of the output current	$60\text{ °C} < T_a \leq 70\text{ °C}$	2.5 %/°C	2.5 %/°C
Maximum deviation with load change statical		±2 %	±0.5 % ±1 % (single mode) ±5 % (parallel mode)
change of output voltage within the input voltage range		±1 %	±0.5 %
Control time		< 2 ms	
Starting time after applying the supply voltage	at I_L	max. 1 s	
	with 3500 µF	-	max. 2 s
	with 7000 µF	max. 1.5 s	-
Rise time	at rated load	max. 150 ms	max. 1.5 s
	with 3500 µF	-	max. 500 ms
	with 7000 µF	max. 500 ms	-
Fall time		max. 150 ms	max. 500 ms
Residual ripple and switching peaks	BW = 20 MHz	50 mV	
Parallel connection		yes, to enable redundancy	configurable, to increase power, up to 3 devices, min. 0.1 I_L - max. 0.9 I_L
Series connection		yes, to increase voltage	yes, to increase voltage, max. 2 devices max. 18 V DC
Resistance to reverse feed		1 s - max. 7.5 V DC	1 s - max. 18 V DC max. 18 V DC
Output circuit - No-load, overload and short-circuit behaviour			
Characteristic curve of output		Hiccup-mode	U/I characteristic curve
Short-circuit protection		continuous short-circuit proof	
Short-circuit behaviour		Hiccup-mode	continuation with output power limiting
Overload protection		output power limiting	
No-load protection		continuous no-load stability	
Starting of capacitive loads		7000 µF	3500 µF 7000 µF

CP-E range

Technical data

Data at $T_a = 25\text{ °C}$, $U_n = 230\text{ V AC}$ and rated values, unless otherwise indicated



Type		CP-E 5/3.0	CP-E 12/2.5	CP-E 12/10.0
General data				
Power dissipation		typ. 5 W	typ. 5.6 W	typ. 24 W
Efficiency		typ. 75 %	typ. 84 %	typ. 84 %
Duty time		100 %		
Dimensions (W x H x D)		22.5 x 90 x 114 mm (0.89 x 3.54 x 4.49 in)	40.5 x 90 x 114 mm (1.59 x 3.54 x 4.49 in)	63.2 x 123.6 x 123.6 mm (2.49 x 4.87 x 4.87 in)
Weight		0.144 kg (0.317 lb)	0.287 kg (0.633 lb)	0.888 kg (1.958 lb)
Material of housing		Plastic		Metal
Mounting		DIN rail (IEC/EN 60715), snap-on mounting without any tool		
Mounting position		horizontal		
Minimum distance to other units	horizontal / vertical	25 mm / 25 mm (0.98 in / 0.98 in)		
Degree of protection	housing / terminals	IP20 / IP20		
Protection class		I		
Electrical connection - input circuit / output circuit				
Wire size	fine-strand with wire end ferrule	0.2-2.5 mm ² (24-14 AWG)		0.2-4 mm ² (24-11 AWG)
	fine-strand without wire end ferrule			0.2-6 mm ² (24-10 AWG)
	rigid			
Stripping length		6 mm (0.24 in)	8 mm (0.31 in)	
Tightening torque	input / output	0.6 Nm (5 lb.in)	1.0 Nm (9 lb.in) / 0.62 Nm (5.5 lb.in)	
Environmental data				
Ambient temperature range	operation	-20...+70 °C	-40...+70 °C	-35...+70 °C
	rated load	-20...+60 °C	-40...+60 °C	-35...+60 °C
	storage	-20...+85 °C	-40...+85 °C	-40...+85 °C
Damp heat (cyclic) (IEC/EN 60068-2-30)		95 RH, % without condensation		
Vibration (sinusoidal) (IEC/EN 60068-2-6)		10-500 Hz, 2 G, along X, Y, Z each axis, 60 min. for each axis		
Shock (half-sine) (IEC/EN 60068-2-27)		15 G, 11 ms, 3 axes, 6 faces, 3 times for each face		
Isolation data				
Rated insulation voltage U_i	input circuit / output circuit	3 kV AC		
	input / PE	1.5 kV AC		
	output / PE	0.5 kV AC; 0.71 kV DC		
Pollution degree		2		
Overvoltage category (UL/IEC/EN 60950-1)		II		
Standards				
Product standard		EN 61204-3		
Low Voltage Directive		2006/95/EC		
EMC directive		2004/108/EC		
RoHS directive		2002/95/EC		
Electrical safety		EN 60950-1, UL 60950-1, UL 508	EN 60950-1, UL 60950-1, UL 508, EN 61558-1, EN 61558-2-17; EN 60204-1 SELV (EN 60950)	
Protective low voltage		SELV (EN 60950)		
Electromagnetic compatibility				
Interference immunity to		IEC/EN 61000-6-2		
electrostatic discharge	IEC/EN 61000-4-2	Level 4 (air discharge 15 kV / contact discharge 8 kV)		
radiated, radio-frequency, electromagnetic field	IEC/EN 61000-4-3	Level 3 (10 V/m)		
electrical fast transient/burst	IEC/EN 61000-4-4	Level 4 (4 kV / 2,5 kHz)	Level 4 (4 kV / 5 kHz)	
surge	IEC/EN 61000-4-5	L-L Level 3 (2 kV) / L-PE Level 4 (4 kV)		
conducted disturbances, induced by radio-frequency fields	IEC/EN 61000-4-6	Level 3 (10 V)		
power frequency magnetic fields	IEC/EN 61000-4-8	Level 4 (30 A/m)		
voltage dips, short interruptions and voltage variations	IEC/EN 61000-4-11	dip: >95 % 10 ms / >30 % 500 ms interruptions: >95 % 5000 ms		
Interference emission		IEC/EN 61000-6-3		
high-frequency radiated	IEC/CISPR 22, EN 55022	Class B		
high-frequency conducted	IEC/CISPR 22, EN 55022	Class B		
limits for harmonic current emissions	IEC/EN 61000-3-2	Class D	Class A	Class D

„Approvals and marks“ on page 3/4.

CP-E range

Technical data

Data at $T_a = 25\text{ °C}$, $U_{in} = 230\text{ V AC}$ and rated values, unless otherwise indicated

Type		CP-E 24/0.75	CP-E 24/1.25	CP-E 24/2.5
Input circuit		L, N		
Rated input voltage U_n		100-240 V AC		
Input voltage range		90-264 V AC / 120-375 V DC	85-264 V AC / 90-375 V DC	
Frequency range AC		47-63 Hz		
Typical input current	at 115 V AC	335 mA	560 mA	1060 mA
	at 230 V AC	210 mA	330 mA	590 mA
Typical power consumption		22.8 W	36.7 W	69.2 W
Inrush current limiting	at 115 V AC	10 A (max. 3 ms)	20 A (max. 3 ms)	20 A (max. 3 ms)
	at 230 V AC	18 A (max. 3 ms)	40 A (max. 3 ms)	40 A (max. 3 ms)
Discharge current	input / output	0.25 mA		
	input / PE	3.5 mA		
Power failure buffering time	at 115 V AC	min. 20 ms	min. 20 ms	
	at 230 V AC	min. 75 ms	min. 30 ms	
Internal input fuse		2 A slow-acting / 250 V AC		
Power factor correction (PFC)		no		
Indication of operational states				
Output voltage	green LED	OK:  : output voltage OK	OUTPUT OK:  : output voltage OK	
	red LED	LOW:  : output voltage too low	-	-
Output circuit		L+, L-, L+, L+, L-, L-		
Rated output voltage		24 V DC		
Tolerance of the output voltage		0 ... +1 %		
Adjustment range of the output voltage		21.6-28.8 V DC	24-28 V DC	
Rated output power		18 W	30 W	60 W
Rated output current I_o	$T_a \leq 60\text{ °C}$	0.75 A	1.25 A	2.5 A
Derating of the output current	$60\text{ °C} < T_a \leq 70\text{ °C}$	2.5 %/°C		
Signalling output for output voltage OK	DC OK	-	transistor	
Maximum deviation with	load change statical	±2 %	±0.5 %	
	change of output voltage within the input voltage range	±1 %	±0.5 %	
Control time		< 2 ms		
Starting time after applying the supply voltage	at I_o	max. 1 s		
	with 3500 µF	-	max. 2 s	-
	with 7000 µF	max. 1.5 s	-	max. 1.5 s
Rise time	at rated load	max. 150 ms		
	with 3500 µF	-	max. 500 ms	-
	with 7000 µF	max. 500 ms	-	max. 500 ms
Fall time		max. 150 ms		
Residual ripple and switching peaks	BW = 20 MHz	50 mV		
Parallel connection		yes, to enable redundancy		
Series connection		yes, to increase voltage		
Resistance to reverse feed		1 s - max. 35 V DC		
Output circuit - No-load, overload and short-circuit behaviour				
Characteristic curve of output		Hiccup-mode	U/I characteristic curve	
Short-circuit protection		continuous short-circuit proof		
Short-circuit behaviour		Hiccup-mode	continuation with output power limiting	
Overload protection		output power limiting		
No-load protection		continuous no-load stability		
Starting of capacitive loads		7000 µF	3500 µF	7000 µF

CP-E range

Technical data

Data at $T_a = 25\text{ °C}$, $U_{in} = 230\text{ V AC}$ and rated values, unless otherwise indicated



Type		CP-E 24/0.75	CP-E 24/1.25	CP-E 24/2.5
General data				
Power dissipation		typ. 4.45 W	typ. 5.5 W	typ. 8.8 W
Efficiency		typ. 77 %	typ. 86 %	typ. 89 %
Duty time		100 %		
Dimensions (W x H x D)		22.5 x 90 x 114 mm (0.89 x 3.54 x 4.49 in)	40.5 x 90 x 114 mm (1.59 x 3.54 x 4.49 in)	
Weight		0.143 kg (0.315 lb)	0.270 kg (0.60 lb)	0.331 kg (0.73 lb)
Material of housing		Plastic		
Mounting		DIN rail (IEC/EN 60715), snap-on mounting without any tool		
Mounting position		horizontal		
Minimum distance to other units	horizontal / vertical	25 mm / 25 mm (0.98 in / 0.98 in)		
Degree of protection	housing / terminals	IP20 / IP20		
Protection class		I		
Electrical connection - input circuit / output circuit				
Wire size	fine-strand with wire end ferrule	0.2-2.5 mm ² (24-14 AWG)		
	fine-strand without wire end ferrule			
	rigid			
Stripping length		6 mm (0.24 in)		
Tightening torque	input / output	0.6 Nm (5 lb.in)		
Environmental data				
Ambient temperature range	operation	-20...+70 °C	-40...+70 °C	
	rated load	-20...+60 °C	-40...+60 °C	
	storage	-20...+85 °C	-40...+85 °C	
Damp heat (cyclic) (IEC/EN 60068-2-30)		95 % RH, without condensation		
Vibration (sinusoidal) (IEC/EN 60068-2-6)		10-500 Hz, 2 G, along X, Y, Z each axis, 60 min. for each axis		
Shock (half-sine) (IEC/EN 60068-2-27)		15 G, 11 ms, 3 axes, 6 faces, 3 times for each face		
Isolation data				
Rated insulation voltage U_i	input circuit / output circuit	3 kV AC		
	input / PE	1.5 kV AC		
	output / PE	0.5 kV AC; 0.71 kV DC		
Pollution degree		2		
Overvoltage category (UL/IEC/EN 60950-1)		II		
Standards				
Product standard		EN 61204-3		
Low Voltage Directive		2006/95/EC		
EMC directive		2004/108/EC		
RoHS directive		2002/95/EC		
Electrical safety		EN 50178, EN 60950-1, UL 60950-1, UL 508	EN 60950-1, UL 60950-1, UL 508, EN 61558-1, EN 61558-2-17; EN 60204-1	
Protective low voltage		SELV (EN 60950)		
Electromagnetic compatibility				
Interference immunity to		IEC/EN 61000-6-2		
electrostatic discharge	IEC/EN 61000-4-2	Level 4 (air discharge 15 kV / contact discharge 8 kV)		
radiated, radio-frequency, electromagnetic field	IEC/EN 61000-4-3	Level 3 (10 V/m)		
electrical fast transient/burst	IEC/EN 61000-4-4	Level 4 (4 kV / 2.5 kHz)	Level 4 (4 kV / 5 kHz)	
surge	IEC/EN 61000-4-5	L-L Level 3 (2 kV) / L-PE Level 4 (4 kV)		
conducted disturbances, induced by radio-frequency fields	IEC/EN 61000-4-6	Level 3 (10 V)		
power frequency magnetic fields	IEC/EN 61000-4-8	Level 4 (30 A/m)		
voltage dips, short interruptions and voltage variations	IEC/EN 61000-4-11	dip: >95 % 10 ms / >30 % 500 ms, interruptions: >95 % 5000 ms		
Interference emission		IEC/EN 61000-6-3		
high-frequency radiated	IEC/CISPR 22, EN 55022	Class B		
high-frequency conducted	IEC/CISPR 22, EN 55022	Class B		
limits for harmonic current emissions	IEC/EN 61000-3-2	Class D	Class A	

„Approvals and marks“ on page 3/4.

CP-E range

Technical data

Data at $T_a = 25\text{ °C}$, $U_{in} = 230\text{ V AC}$ and rated values, unless otherwise indicated

Type		CP-E 24/5.0	CP-E 24/10.0	CP-E 24/20.0
Input circuit		L, N		
Rated input voltage U_{in}		115 / 230 V AC auto select		115-230 V AC
Input voltage range		90-132 V AC, 180-264 V AC / 210-375 V DC	90-132 V AC, 180-264 V AC / 210-375 V DC	90-264 V AC, 120-375 V DC
Frequency range AC		47-63 Hz		
Typical input current	at 115 V AC	2.2 A	4.0 A	4.9 A
	at 230 V AC	0.83 A	1.55 A	2.5 A
Typical power consumption		140 W	270 W	539 W
Inrush current limiting	at 115 V AC	24 A (max. 5 ms)	30 A (max. 5 ms)	25 A (max. 5 ms)
	at 230 V AC	48 A (max. 5 ms)	60 A (max. 5 ms)	50 A (max. 5 ms)
Discharge current	input / output	0.25 mA		
	input / PE	3.5 mA		
Power failure buffering time	at 115 V AC	min. 25 ms		
	at 230 V AC	min. 30 ms		
Internal input fuse		3.15 A slow-acting / 250 V AC	6.3 A slow-acting / 250 V AC	10 A slow-acting / 250 V AC
Power factor correction (PFC)		yes, passive, 0.7		yes, active 115 V AC: 0.99 230 V AC: 0.97
Indication of operational states				
Output voltage	green LED	OUTPUT OK:  : output voltage OK		
	red LED	OUTPUT LOW:  : output voltage too low		
Output circuit		L+, L+, L-, L-		
Rated output voltage		24 V DC		
Tolerance of the output voltage		0..+1 %		
Adjustment range of the output voltage		22.5-28.5 V DC		
Rated output power		120 W	240 W	480 W
Rated output current I_L	$T_a \leq 60\text{ °C}$	5 A	10 A	-
	$T_a \leq 55\text{ °C}$	-	-	20 A
Derating of the output current	$60\text{ °C} < T_a \leq 70\text{ °C}$	2.5 %/°C		-
	$55\text{ °C} < T_a \leq 70\text{ °C}$	-	-	2.5 %/°C
Signalling contact for output voltage OK	13-14	solid-state (max. 60 V DC, 0.3 A)		
Minimum fuse rating to achieve short-circuit protection	13-14	$\geq 60\text{ V DC}$, $\leq 0.3\text{ A}$ fast-acting		
Maximum deviation with	load change statical	$\pm 1\%$ (single mode), $\pm 5\%$ (parallel mode)		
	change of output voltage within the input voltage range	$\pm 0.5\%$		
Control time		< 2 ms		
Starting time after applying the supply voltage	at I_L	max. 1 s		
	with 3500 μF	max. 1.5 s	-	-
	with 7000 μF	-	max. 1.5 s	
Rise time	at rated load	max. 150 ms		
	with 3500 μF	max. 500 ms	-	-
	with 7000 μF	-	max. 500 ms	
Fall time		max. 150 ms		
Residual ripple and switching peaks	BW = 20 MHz	50 mV	100 mV	
Parallel connection		configurable, to increase power, up to 3 devices, min. 0.1 I_L - max. 0.9 I_L		
Series connection		yes, to increase voltage, max. 2 devices		
Resistance to reverse feed		max. 35 V DC		
Output circuit - No-load, overload and short-circuit behaviour				
Characteristic curve of output		U/I characteristic curve		
Short-circuit protection		continuous short-circuit proof		
Short-circuit behaviour		continuation with output power limiting		
Overload protection		output power limiting		
No-load protection		continuous no-load stability		
Starting of capacitive loads		3500 μF	7000 μF	

CP-E range

Technical data

Data at $T_a = 25\text{ °C}$, $U_{in} = 230\text{ V AC}$ and rated values, unless otherwise indicated

Type		CP-E 24/5.0	CP-E 24/10.0	CP-E 24/20.0
General data				
Power dissipation		typ. 20 W	typ. 35 W	typ. 63 W
Efficiency		typ. 86 %	typ. 89 %	typ. 89 %
Duty time		100 %		
Dimensions (W x H x D)		63.2 x 123.6 x 123.6 mm (2.49 x 4.87 x 4.87 in)	83 x 123.6 x 123.6 mm (3.27 x 4.87 x 4.87 in)	175 x 123.6 x 123.6 mm (6.89 x 4.87 x 4.87 in)
Weight		0.882 kg (1.945 lb)	1.334 kg (2.941 lb)	1.850 kg (4.079 lb)
Material of housing		Metal		
Mounting		DIN rail (IEC/EN 60715), snap-on mounting without any tool		
Mounting position		horizontal		
Minimum distance to other units	horizontal / vertical	25 mm / 25 mm (0.98 in / 0.98 in)		
Degree of protection	housing / terminals	IP20 / IP20		
Protection class		I		
Electrical connection - input circuit / output circuit				
Wire size	fine-strand with wire end ferrule	0.2-4 mm ² (24-11 AWG)		
	fine-strand without wire end ferrule	0.2-6 mm ² (24-10 AWG)		
	rigid			
Stripping length		8 mm (0.31 in)		
Tightening torque	input / output	1.0 Nm (9 lb.in) / 0.62 Nm (5.5 lb.in)		
Environmental data				
Ambient temperature range	operation	-35...+70 °C	-40...+70 °C	
	rated load	-35...+60 °C	-40...+60 °C	-40...+55 °C
	storage	-40...+85 °C	-40...+85 °C	
Damp heat (cyclic) (IEC/EN 60068-2-30)		95 %RH, without condensation		
Vibration (sinusoidal) (IEC/EN 60068-2-6)		10-500 Hz, 2 G, along X, Y, Z each axis, 60 min. for each axis		
Shock (half-sine) (IEC/EN 60068-2-27)		15 G, 11 ms, 3 axes, 6 faces, 3 times for each face		
Isolation data				
Rated insulation voltage U_i	input circuit / output circuit	3 kV AC		
	input / PE	1.5 kV AC		
	output / PE	0.5 kV AC; 0.71 kV DC		
	signalling contact / PE	0.5 kV DC		
Pollution degree		2		
Overvoltage category (UL/IEC/EN 60950-1)		II		
Standards				
Product standard		EN 61204-3		
Low Voltage Directive		2006/95/EC		
EMC directive		2004/108/EC		
RoHS directive		2002/95/EC		
Electrical safety		EN 60950-1, UL 60950-1, UL 508, EN 61558-1, EN 61558-2-17; EN 60204-1		
Protective low voltage		SELV (EN 60950)		
Electromagnetic compatibility				
Interference immunity to		IEC/EN 61000-6-2		
electrostatic discharge	IEC/EN 61000-4-2	Level 4 (air discharge 15 kV / contact discharge 8 kV)		
radiated, radio-frequency, electromagnetic field	IEC/EN 61000-4-3	Level 3 (10 V/m)		
electrical fast transient/burst	IEC/EN 61000-4-4	Level 4 (4 kV / 5 kHz)	Level 4 (4 kV / 2.5 kHz)	
surge	IEC/EN 61000-4-5	L-L Level 3 (2 kV) / L-PE Level 4 (4 kV)		
conducted disturbances, induced by radio-frequency fields	IEC/EN 61000-4-6	Level 3 (10 V)		
power frequency magnetic fields	IEC/EN 61000-4-8	Level 4 (30 A/m)		
voltage dips, short interruptions and voltage variations	IEC/EN 61000-4-11	dip: >95 % 10 ms / >30 % 500 ms interruptions: >95 % 5000 ms		
Interference emission		IEC/EN 61000-6-3		
high-frequency radiated	IEC/CISPR 22, EN 55022	Class B		
high-frequency conducted	IEC/CISPR 22, EN 55022	Class B		
limits for harmonic current emissions		Class D		

„Approvals and marks“ on page 3/4.

CP-E range

Technical data

Data at $T_a = 25\text{ °C}$, $U_{in} = 230\text{ V AC}$ and rated values, unless otherwise indicated

Type	CP-E 48/0.62	CP-E 48/1.25	CP-E 48/5.0	CP-E 48/10.0
Input circuit				
L, N				
Rated input voltage U_n	100-240 V AC		115 / 230 V AC auto select	115-230 V AC
Input voltage range	85-264 V AC / 90-375 V DC		90-132 V AC, 180-264 V AC / 210-375 V DC	90-264 V AC, 120-375 V DC
Frequency range AC	47-63 Hz			
Typical input current	at 115 V AC 560 mA	1060 mA	4.0 A	4.9 A
	at 230 V AC 330 mA	590 mA	1.55 A	2.5 A
Typical power consumption	35.7 W	69.0 W	267 W	528 W
Inrush current limiting	at 115 V AC 20 A (max. 3 ms)	20 A (max. 3 ms)	30 A (max. 5 ms)	25 A (max. 5 ms)
	at 230 V AC 40 A (max. 3 ms)	40 A (max. 3 ms)	60 A (max. 5 ms)	50 A (max. 5 ms)
Discharge current	input / output 0.25 mA			
	input / PE 3.5 mA			
Power failure buffering time	at 115 V AC min. 20 ms		min. 25 ms	min. 25 ms
	at 230 V AC min. 30 ms			
Internal input fuse	2 A slow-acting / 250 V AC		6.3 A slow-acting / 250 V AC	10 A slow-acting / 250 V AC
Power factor correction (PFC)	no		yes, passive, 0.7	yes, active 115 V AC: 0.99 230 V AC: 0.97
Indication of operational states				
Output voltage	green LED	OUTPUT OK: <input type="checkbox"/> L: output voltage OK		
	red LED	-	OUTPUT LOW: <input type="checkbox"/> L: output voltage too low	
Output circuit				
L+, L+, L-, L-				
Rated output voltage	48 V DC			
Tolerance of the output voltage	0...+1 %			
Adjustment range of the output voltage	48-55 V DC		47-56 V DC	
Rated output power	30 W	60 W	240 W	480 W
Rated output current I_L	$T_a \leq 60\text{ °C}$ 0.625 A	1.25 A	5 A	-
	$T_a \leq 55\text{ °C}$ -	-	-	10 A
Derating of the output current	$60\text{ °C} < T_a \leq 70\text{ °C}$ 2.5 %/°C	-	-	-
	$55\text{ °C} < T_a \leq 70\text{ °C}$ -	-	-	2.5 %/°C
Signalling output for output voltage OK	DC OK	-	-	-
Maximum deviation with load change statical	±0.5 %		±1 % (single mode) ±5 % (parallel mode)	
	change of output voltage within the input voltage range	±0.5 %	±0.5 %	
Control time	< 2 ms			
Starting time after applying the supply voltage	at I_L max. 1 s			
	with 3500 µF max. 2 s	-	-	-
	with 7000 µF -	max. 1.5 s	max. 1.5 s	
Rise time	at rated load max. 150 ms			
	with 3500 µF max. 500 ms	-	-	-
	with 7000 µF -	max. 500 ms	max. 500 ms	
Fall time	max. 150 ms			
Residual ripple and switching peaks	BW = 20 MHz	50 mV	100 mV	
Parallel connection	yes, to enable redundancy		configurable, to increase power, up to 3 devices, min. 0.1 I_L - max. 0.9 I_L	
Series connection	yes, to increase voltage		yes, to increase voltage, max. 2 devices	
Resistance to reverse feed	1 s - max. 63 V DC			
Output circuit - No-load, overload and short-circuit behaviour				
Characteristic curve of output	U/I characteristic curve			
Short-circuit protection	continuous short-circuit proof			
Short-circuit behaviour	continuation with output power limiting			
Overload protection	output power limiting			
No-load protection	continuous no-load stability			
Starting of capacitive loads	3500 µF	7000 µF	unlimited	7000 µF

CP-E range

Technical data

Data at $T_a = 25\text{ °C}$, $U_n = 230\text{ V AC}$ and rated values, unless otherwise indicated

Type	CP-E 48/0.62	CP-E 48/1.25	CP-E 48/5.0	CP-E 48/10.0
General data				
Power dissipation	typ. 4.9 W	typ. 7.8 W	typ. 32 W	typ. 60 W
Efficiency	typ. 86 %	typ. 89 %	typ. 90 %	
Duty time	100 %			
Dimensions (W x H x D)	40.5 x 90 x 114 mm (1.59 x 3.54 x 4.49 in)		83 x 123.6 x 123.6 mm (3.27 x 4.87 x 4.87 in)	175 x 123.6 x 123.6 mm (6.89 x 4.87 x 4.87 in)
Weight	0.264 kg (0.582 lb)	0.316 kg (0.697 lb)	1.322 kg (2.915 lb)	1.839 kg (4.054 lb)
Material of housing	Plastic		Metal	
Mounting	DIN rail (IEC/EN 60715), snap-on mounting without any tool			
Mounting position	horizontal			
Minimum distance to other units	horizontal / vertical		25 mm / 25 mm (0.98 in / 0.98 in)	
Degree of protection	housing / terminals		IP/20 / IP20	
Protection class	I			
Electrical connection - input circuit / output circuit				
Wire size	fine-strand with wire end ferrule		0.2-4 mm ² (24-11 AWG)	
	fine-strand without wire end ferrule		0.2-2.5 mm ² (24-14 AWG)	
	rigid		0.2-6 mm ² (24-10 AWG)	
Stripping length	6 mm (0.24 in)		8 mm (0.31 in)	
Tightening torque	input / output		0.6 Nm (5 lb.in) / 1.0 Nm (9 lb.in) / 0.62 Nm (5.5 lb.in)	
Environmental data				
Ambient temperature range	operation		-40...+70 °C	
	rated load		-40...+60 °C	
	storage		-40...+85 °C	
Damp heat (cyclic) (IEC/EN 60068-2-30)	95 % RH, without condensation			
Vibration (sinusoidal) (IEC/EN 60068-2-6)	10-500 Hz, 2 G, along X, Y, Z each axis, 60 min. for each axis			
Shock (half-sine) (IEC/EN 60068-2-27)	15 G, 11 ms, 3 axes, 6 faces, 3 times for each face			
Isolation data				
Rated insulation voltage U_i	input circuit / output circuit		3 kV AC	
	input / PE		1.5 kV AC	
	output / PE		0.5 kV AC; 0.71 kV DC	
Pollution degree	2			
Overvoltage category (UL/IEC/EN 60950-1)	II			
Standards				
Product standard	EN 61204-3			
Low Voltage Directive	2006/95/EC			
EMC directive	2004/108/EC			
RoHS directive	2002/95/EC			
Electrical safety	EN 60950-1, UL 60950-1, UL 508, EN 61558-1, EN 61558-2-17; EN 60204-1			
Protective low voltage	SELV (EN 60950)			
Electromagnetic compatibility				
Interference immunity to	IEC/EN 61000-6-2			
electrostatic discharge	IEC/EN 61000-4-2	Level 4 (air discharge 15 kV / contact discharge 8 kV)		
radiated, radio-frequency, electromagnetic field	IEC/EN 61000-4-3	Level 3 (10 V/m)		
electrical fast transient/burst	IEC/EN 61000-4-4	Level 4 (4 kV / 5 kHz)	Level 4 (4 kV / 2.5 kHz)	
surge	IEC/EN 61000-4-5	L-L Level 3 (2 kV) / L-PE Level 4 (4 kV)		
conducted disturbances, induced by radio-frequency fields	IEC/EN 61000-4-6	Level 3 (10 V/m)		
power frequency magnetic fields	IEC/EN 61000-4-8	Level 4 (30 A/m)		
voltage dips, short interruptions and voltages variations	IEC/EN 61000-4-11	dip: >95 % 10 ms / >30 % 500 ms, interruptions: >95 % 5000 ms		
Interference emission	IEC/EN 61000-6-3			
high-frequency radiated	IEC/CISPR 22, EN 55022	Class B		
high-frequency conducted	IEC/CISPR 22, EN 55022	Class B		
limits for harmonic current emissions	Class A		Class D	

„Approvals and marks“ on page 3/4.

CP-E range

Technical diagrams, Wiring instructions

Output curve at $T_a = 25^\circ\text{C}$

3

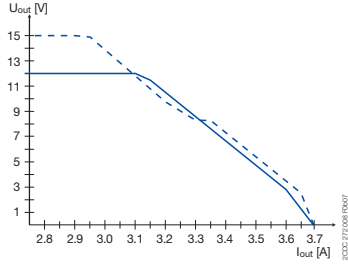

CP-E 12/2.5

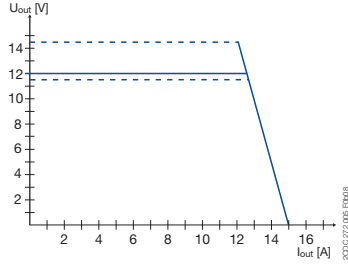

CP-E 12/10.0

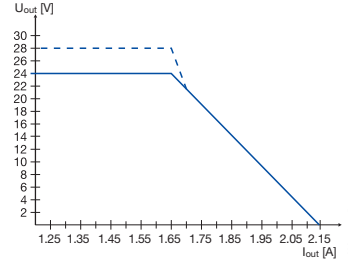

CP-E 24/1.25

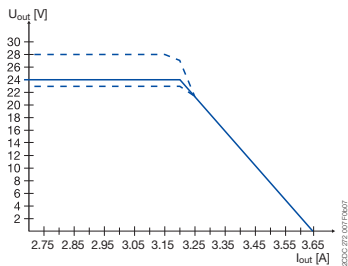

CP-E 24/2.5

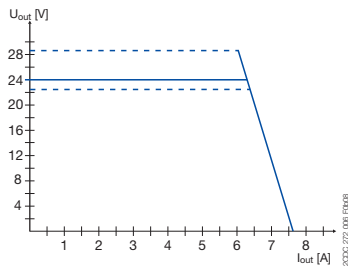

CP-E 24/5.0

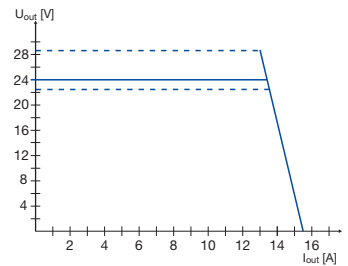

CP-E 24/10.0

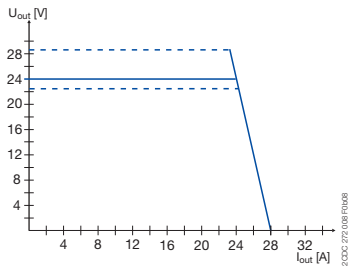

CP-E 24/20.0

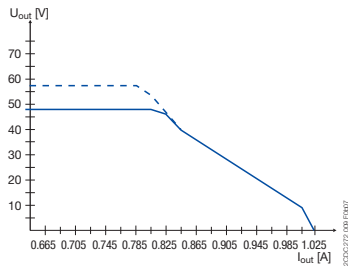

CP-E 48/0.62

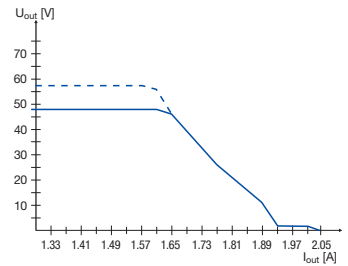

CP-E 48/1.25

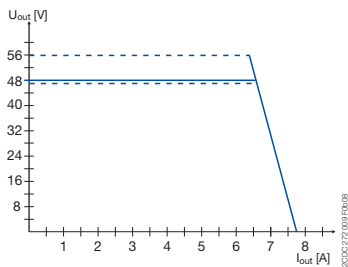

CP-E 48/5.0

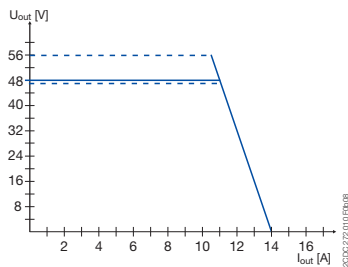

CP-E 48/10.0

Wiring instructions

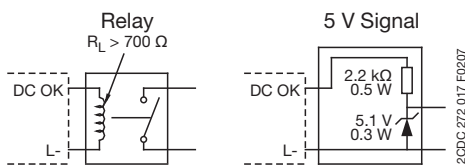

CP-E 24/1.25, CP-E 24/2.5

CP-E range

Technical diagrams, Dimensional drawings

Temperature behaviour at $T_a = 25\text{ }^\circ\text{C}$

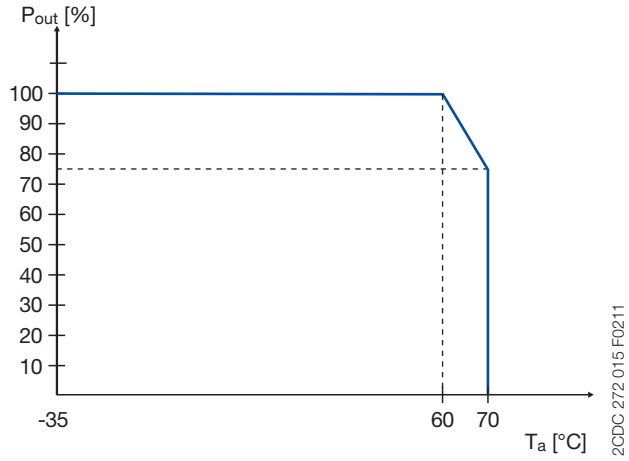

CP-E 12/10.0, CP-E 24/5.0

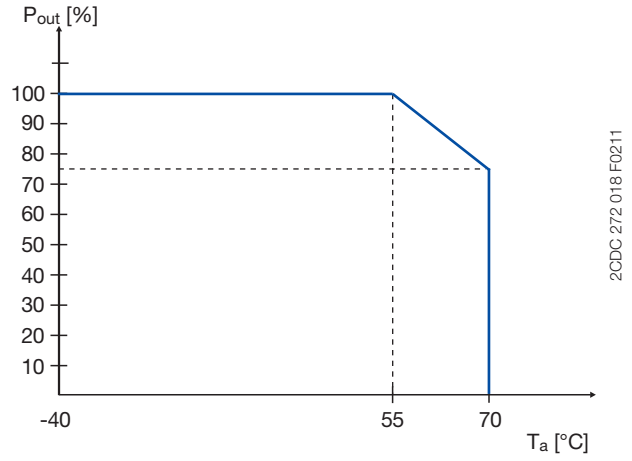

CP-E 24/20.0, CP-E 48/10.0

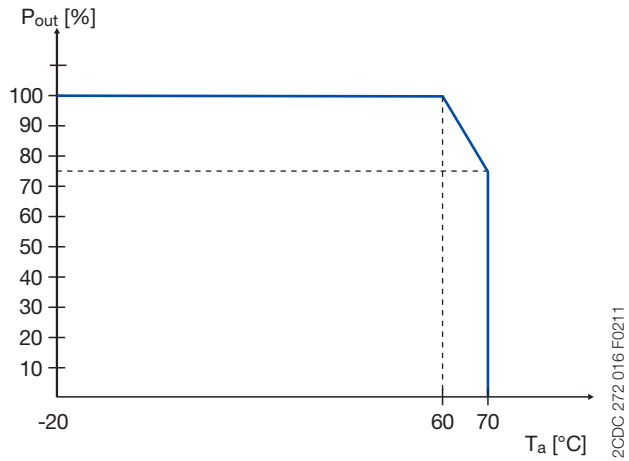

CP-E 5/3.0, CP-E 24/0.75

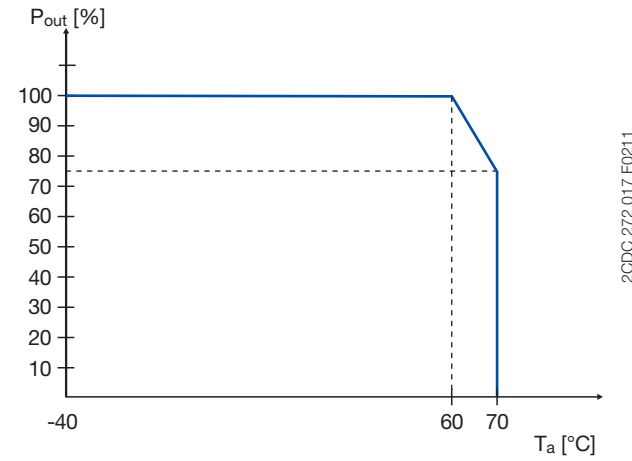

CP-E 12/2.5, CP-E 24/1.25, CP-E 48/0.62,
CP-E 24/2.5, CP-E 48/1.25, CP-E 24/10.0, CP-E 48/5.0

Dimensional drawings

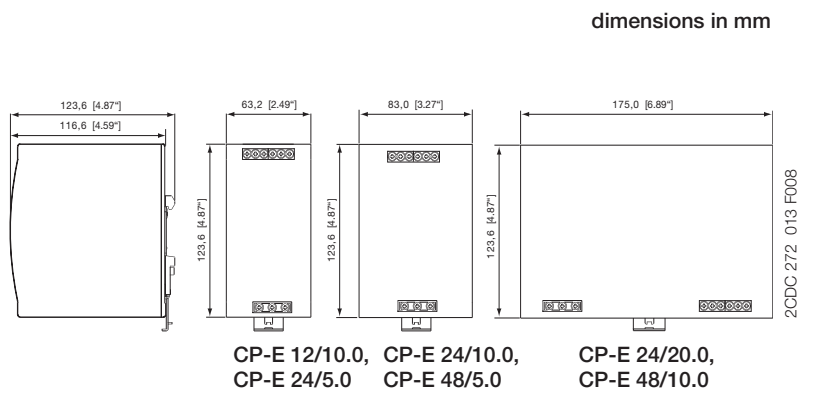
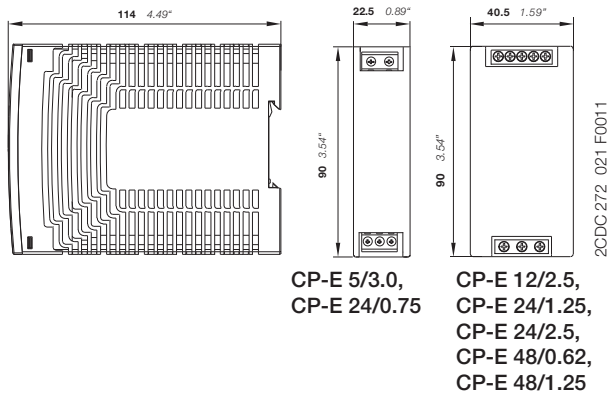

dimensions in mm

CP-T range Product group picture

3



CP-T range

Table of contents

CP-T range	
Product group picture	3/31
Table of contents	3/32
Benefits and advantages	3/33
Ordering details	3/34
Technical data	3/35
Technical diagrams, Dimensional drawings	3/39
Technical diagrams	3/40

CP-T range

Benefits and advantages

Characteristics

- Rated output voltages 24 V, 48 V DC
- Output voltage adjustable via front-face rotary potentiometer "OUTPUT Adjust"
- Rated output currents 5 A, 10 A, 20 A, 40 A
- Rated output powers 120 W, 240 W, 480 W, 960 W
- Three-phase or two-phase operation (see derating note)
- Supply range 3 x 400 – 500 V AC (3 x 340 – 575 V AC, 480 – 820 V DC)
- Typical efficiency of 93 %
- Low power dissipation and low heating
- Free convection cooling (no forced cooling with ventilators)
- Ambient temperature range during operation -40...+70 °C ¹⁾
- Open-circuit, overload and short-circuit stable
- Integrated input fuse
- Redundancy unit CP-A RU offering true redundancy, available as accessory
- LEDs for status indication
- Signalling contact "13-14" (solid state) for output voltage OK
- Approvals / marks (depending on device, partly pending):



¹⁾ 480 W variants: -30...+70°C

Benefits

Signalling output ①

The devices of the CP-T series offer a solid state output for function monitoring and remote diagnostics.

Wide input range

Wide range input optimized for world-wide applications: The CP-T power supplies can be used in 340 - 575 V AC or 480 - 820 V DC supply systems.

Adjustable output voltage ②

The CP-T range feature a continuously adjustable output voltage. Thus, they can be optimally adapted to the application, e.g. compensating the voltage drop caused by a long line length.

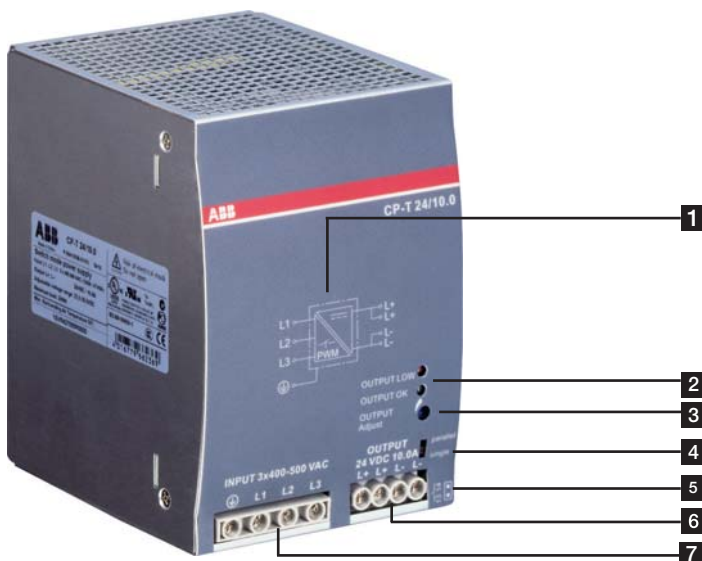
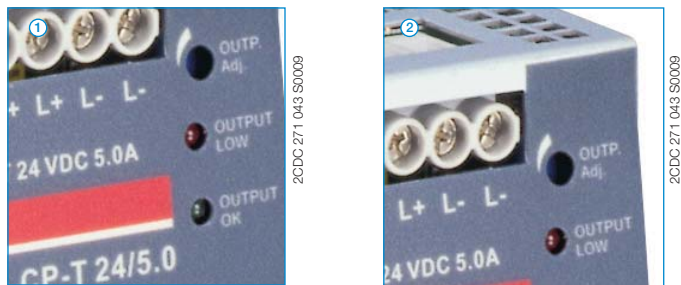

1 Circuit diagram

2 Indication of operational states

DC ON: green LED - green LED - output voltage OK

DC LOW: red LED - output voltage too low

3 single/parallel: sliding switch - adjustment of single or parallel operation

4 Configuration of single or parallel operation

5 Signalling contact

OUTPUT 13-14: terminals - signalling contact

A solid-state output indicates the error-free operation of the output voltage.

6 OUTPUT L+, L+, L-, L-: terminals - output

7 INPUT L1, L2, L3, PE: terminals - input

CP-T range

Ordering details



2CDC 271 048 S0009

CP-T 24/5.0



2CDC 271 048 S0009

CP-T 24/10.0, CP-T 48/5.0



2CDC 271 047 S0009

CP-T 24/20.0, CP-T 48/10.0

Description

The CP-T range of three-phase power supply units is the youngest member of ABB's power supply family. In terms of design and functionality, the new range perfectly supplements the existing products and extends the range appropriately. The devices can be supplied with a three-phase voltage as well as with two-phase mains. Here, ABB offers power supply units with 24 V DC and 48 V DC outputs with 5 A, 10 A, 20 A and 40 A and efficiency of up to 92 %. As in the case of all products, they are designed for an ambient temperature of up to 70 °C. All products can be supplied within an AC supply voltage range between 340 to 575 V AC and a DC supply voltage range between 480 to 820 V DC.

Ordering details

Input voltage range	Rated output voltage / current	Type	Order code	Price 1 pce	Weight (1 pce) kg (lb)
340-575 V AC / 480-820 V DC	24 V DC / 5 A	CP-T 24/5.0	1SVR427054R0000		0.80 (1.77)
340-575 V AC / 480-820 V DC	24 V DC / 10 A	CP-T 24/10.0	1SVR427055R0000		1.05 (2.31)
340-575 V AC / 480-820 V DC	24 V DC / 20 A	CP-T 24/20.0	1SVR427056R0000		1.75 (3.86)
340-575 V AC / 480-820 V DC	24 V DC / 40 A	CP-T 24/40.0	1SVR427057R0000		3.20 (7.05)
340-575 V AC / 480-820 V DC	48 V DC / 5 A	CP-E 48/5.0	1SVR427054R2000		1.05 (2.31)
340-575 V AC / 480-820 V DC	48 V DC / 10 A	CP-E 48/10.0	1SVR427055R2000		1.75 (3.86)
340-575 V AC / 480-820 V DC	48 V DC / 20 A	CP-E 48/20.0	1SVR427056R2000		3.40 (7.50)

CP-T range

Technical data

Data at $T_a = 25\text{ °C}$, $U_{in} = 3 \times 400\text{ V AC}$ and rated values, unless otherwise indicated

Type	CP-T 24/5.0	CP-T 24/10.0	CP-T 24/20.0	CP-T 24/40.0
Input circuit				
L1, L2, L3				
Rated input voltage U_n	3 x 400-500 V AC			
Input voltage range	340-575 V AC 480-820 V DC			
Frequency range AC	47-63 Hz			
Typical input current	0.36 A	0.65 A	1.1 A	1.72 A
Typical power consumption	135 W	270 W	538 W	1058 W
Inrush current limiting	10 A	20 A		30 A
Power failure buffering time	min. 20 ms			min. 15 ms
Internal input fuse	per phase 2 A / 600 V AC		T 3.15 A / 500 V AC	T 5 A / 500 V AC
Recommended backup fuse	3 pole miniature circuit breaker ABB Type S203			
Power factor correction (PFC)	Yes, passive			
Discharge current	towards PE input / output < 0.25 mA			
Indication of operational states				
Output voltage	OUTPUT OK: green LED OUTPUT LOW: red LED		output voltage OK output voltage too low	
Output circuit				
L+, L+, L-, L-				
Rated output voltage	24 V DC			
Tolerance of the output voltage	0...+1 %			
Adjustment range of the output voltage	22.5-28.5 V DC			
Rated output power	120 W	240 W	480 W	960 W
Rated output current I_r	$T_a \leq 60\text{ °C}$ 5 A	10 A	20 A	40 A
Derating of the output current	$60\text{ °C} < T_a \leq 70\text{ °C}$	2.5 %/°C		3.5 %/°C
Signalling contact for output voltage OK	13-14	solid state (max. 60 V DC, 0.3 A)		
	Threshold	17.6-19.4 V		
	Insulation voltage	500 V DC		
Minimum fuse rating to achieve short-circuit protection	13-14	$\geq 60\text{ V DC}$, $\leq 0.3\text{ A}$ fast-acting		
Maximum deviation with	load change statical	$\pm 1\%$	$\pm 1\%$ (single mode) $\pm 5\%$ (parallel mode)	
	change of output voltage within the input voltage range	$\pm 0.5\%$		
Control time	at nominal load	< 2 ms		
Starting time after applying the supply voltage	at I_r	max. 1 s		
	with 3500 μF	max. 1.5 s		
Rise time	at nominal load	max. 150 ms		
	with 3500 μF	max. 500 ms		
Fall time		max. 150 ms		
Residual ripple and switching peaks	BW = 20 MHz	100 mV		80 mV
Parallel connection		not supported	configurable, to increase power, up to 2 devices, min. 0.1 I_r - max 0.9 I_r)	to increase power, up to 2 devices, min. 0.1 I_r - max. 0.9 I_r , use active current balancing
Series connection		not supported	yes, to increase voltage, max. 2 devices	
Resistance to reverse feed		approx. 35 V		
Output circuit - No-load, overload and short-circuit behaviour				
Characteristic curve of output	combined U/I characteristic curve and hiccup mode		U/I- or Hiccup-mode adjustable	hiccup / fold back behavior
Short-circuit protection	continuous short-circuit proof			
Short-circuit behaviour	current limiting			
Overload protection	hiccup mode			
No-load protection	continuous no-load stability			
Overtemperature protection	yes, automatic recovery after temperature went down			
Starting of capacitive loads	3500 μF	7000 μF	7000 μF	7000 μF

CP-T range

Technical data

Data at $T_a = 25\text{ °C}$, $U_n = 3 \times 400\text{ V AC}$ and rated values, unless otherwise indicated

Type	CP-T 24/5.0	CP-T 24/10.0	CP-T 24/20.0	CP-T 24/40.0
General data				
Efficiency	typ. 89 %	typ. 90 %		typ. 92 %
Duty time	100%			
Dimensions (W x H x D)	74.3 x 124 x 118.8 mm (2.92 x 4.88 x 4.68 in)	89 x 124 x 118.8 mm (3.5 x 4.88 x 4.68 in)	150 x 124 x 118.8 mm (5.91 x 4.88 x 4.68 in)	275.8 x 124 x 118.8 mm (10.86 x 4.88 x 4.68 in)
Weight	0.78 kg (1.72 lb)	1.045 kg (2.30 lb)	1.657 kg (3.653 lb)	3.275 kg (7.220 lb)
Material of housing	Metal			
Mounting	DIN rail (IEC EN 60715), snap-on mounting without any tool			
Mounting position	horizontal			
Minimum distance to other units	horizontal / vertical 25 mm / 25 mm (0.98 in / 0.98 in)			
Degree of protection	housing / terminals IP20 / IP20			
Protection class	I			
Electrical connection - input circuit / output circuit / signalling circuit				
Wire size	fine-strand with wire end ferrule	0,2-4 mm ² (24-11 AWG)		
	fine-strand without wire end ferrule	0,2-6 mm ² (24-10 AWG)		
	rigid	0,2-6 mm ² (24-10 AWG)		
Stripping length	8 mm (0.31 in)			
Tightening torque	input / output	1 Nm (9 lb.in) / 0.6 Nm (5.5 lb.in)		1 Nm (9 lb.in) / 1.8 Nm (15.6 lb.in)
Environmental data				
Ambient temperature range	operation	-40...+70 °C	-30...+70 °C	-40...+70 °C
	rated load	-40...+60 °C	-30...+60 °C	-40...+60 °C
	storage	-40...+85 °C		
Damp heat (cyclic) (IEC/EN 60068-2-30)	95 % without condensation			
Vibration (sinusoidal) (IEC/EN 60068-2-6)	2 g, 10-500 Hz, 2G, each along X, Y, Z axes 60 min / cycle			
Shock (half-sine) (IEC/EN 60068-2-27)	15 g, 11 ms, 3 axes, 6 faces, 3 times for each face			
Isolation data				
Rated insulation voltage U_i	input circuit / output circuit	3 kV AC		
	input / PE	1.5 kV AC		
	output / PE	0.5 kV AC; 0.71 kV DC		
	signalling output / PE	0.5 kV DC		
Pollution degree	2			
Standards				
Product standard	EN 61204-3			
Low Voltage Directive	2006/95/EC			
EMC directive	2004/108/EC			
RoHS directive	2002/95/EC			
Electrical safety	EN 60950-1, UL 60950-1, UL 508, EN 61558-1, EN 61558-2-17; EN 60204-1			
Protective low voltage	SELV			
Electromagnetic compatibility				
Interference immunity to	IEC/EN 61000-6-2			
electrostatic discharge	IEC/EN 61000-4-2	Level 4 (air discharge 15 kV / contact discharge 8 kV)		
radiated, radio-frequency, electromagnetic field	IEC/EN 61000-4-3	Level 3 (10 V/m)		
electrical fast transient/burst	IEC/EN 61000-4-4	Level 4 (4 kV / 2.5 kHz)	Level 4 (4 kV / 5 kHz)	
surge	IEC/EN 61000-4-5	L-L Level 3 (2 kV) / L-PE Level 4 (4 kV)		
conducted disturbances, induced by radio-frequency fields	IEC/EN 61000-4-6	Level 3 (10 V)		
power frequency magnetic fields	IEC/EN 61000-4-8	Level 4 (30 A/m)		
voltage dips, short interruptions and voltage variations	IEC/EN 61000-4-11	dips: >95 % 0.5 ms / >30 % 0.5 ms, interruptions: >95 % 250 ms		
Interference emission	IEC/EN 61000-6-3			
high-frequency radiated	IEC/CISPR 22, EN 55022	Class B		
high-frequency conducted	IEC/CISPR 22, EN 55022	Class B		
limits for harmonic current emissions	IEC/EN 61000-3-2	Class A		

„Approvals and marks“ on page 3/4.

CP-T range

Technical data

Data at $T_a = 25\text{ °C}$, $U_{in} = 3 \times 400\text{ V AC}$ and rated values, unless otherwise indicated

Type	CP-T 48/5.0	CP-T 48/10.0	CP-T 48/20.0
Input circuit			
Rated input voltage U_n	3 x 400-500 V AC		
Input voltage range	340-575 V AC 480-820 V DC		
Frequency range AC	47-63 Hz		
Typical input current	0.65 A	1.1 A	1.72 A
Typical power consumption	264 W	535 W	1050 W
Inrush current limiting	20 A		30 A
Power failure buffering time	min. 20 ms		min. 15 ms
Internal input fuse	per phase 2 A / 600 V AC	T3.15 A / 500 V AC	T 5 A / 500 V AC
Power factor correction (PFC)	yes, passive		
Discharge current	towards PE < 3.5 mA		
	input / output < 0.25 mA		
Indication of operational states			
Output voltage	OUTPUT OK: green LED OUTPUT LOW: red LED	output voltage OK output voltage too low	
Output circuit			
Rated output voltage	48 V DC		
Tolerance of the output voltage	0...+1 %		
Adjustment range of the output voltage	47-56 V DC		
Rated output power	240 W	480 W	960 W
Rated output current I_r	$T_a \leq 60\text{ °C}$ 5 A	10 A	20 A
Derating of the output current	$60\text{ °C} < T_a \leq 70\text{ °C}$ 2.5 %/°C	3.5 %/°C	
Maximum deviation with	load change statical	$\pm 1\%$ (single mode) $\pm 5\%$ (parallel mode)	
	change of output voltage within the input voltage range	$\pm 0.5\%$	
Control time	at rated load	< 2 ms	
Starting time after applying the supply voltage	at I_r	max. 1 s	
	with 7000 μF	max. 1.5 s	
Rise time	at rated load	max. 150 ms	
	with 7000 μF	max. 500 ms	
Fall time	max. 150 ms		
Residual ripple and switching peaks	BW = 20 MHz	100 mV	80 mV
Parallel connection	configurable, to increase power, up to 2 devices, min. 0.1 I_r - max 0.9 I_r)		to increase power, up to 2 devices, min. 0.1 I_r - max. 0.9 I_r use active current balancing
Series connection	yes, to increase voltage, max. 2 devices		
Resistance to reverse feed	approx. 35 V	approx. 63 V	approx. 63 V
Output circuit - No-load, overload and short-circuit behaviour			
Characteristic curve of output	combined U/I and hiccup mode	U/I or hiccup mode, configurable	hiccup mode / fold back behavior
Short-circuit protection	continuous short-circuit proof		
Short-circuit behaviour	current limiting		
Overload protection	hiccup mode		
No-load protection	continuous no-load stability		
Over temperature protection	yes, automatic recovery after temperature went down		
Starting of capacitive loads	7000 μF		

CP-T range

Technical data

Data at $T_a = 25\text{ °C}$, $U_{in} = 3 \times 400\text{ V AC}$ and rated values, unless otherwise indicated

Type		CP-T 48/5.0	CP-T 48/10.0	CP-T 48/20.0
General data				
Efficiency		typ. 91 %		typ. 93 %
Duty time		100%		
Dimensions (W x H x D)		89 x 124 x 118.8 mm (3.5 x 4.88 x 4.68 in)	150 x 124 x 118.8 mm (5.91 x 4.88 x 4.68 in)	275.8 x 124 x 118.8 mm (10.86 x 4.88 x 4.68 in)
Weight		1.045 kg (2.30 lb)	1.657 kg (3.653 lb)	3.275 kg (7.22 lb)
Material of housing		Metal		
Mounting		DIN rail (IEC EN 60715), snap-on mounting without any tool		
Mounting position		horizontal		
Minimum distance to other units	horizontal / vertical	25 mm / 25 mm (0.98 in / 0.98 in)		
Degree of protection	housing / terminals	IP20 / IP20		
Protection class		I		
Electrical connection - input circuit / output circuit				
Wire size	fine-strand with wire end ferrule	0.2-4 mm ² (24-11 AWG)		0.2-4 mm ² (24-11 AWG) / 0.5-10 mm ² (20-8 AWG)
	fine-strand without wire end ferrule	0.2-6 mm ² (24-10 AWG)		
	rigid			
Stripping length		8 mm (0.31 in)		
Tightening torque	input / output	1 Nm (9 lb.in) / 0.6 Nm (5.5 lb.in)		1 Nm (9 lb.in) / 1.8 Nm (15.6 lb.in)
Environmental data				
Ambient temperature range	operation	-40...+70 °C	-30...+70 °C	-40...+70 °C
	rated load	-40...+60 °C	-30...+60 °C	-40...+60 °C
	storage	-40...+85 °C	-40...+85 °C	-40...+85 °C
Damp heat (cyclic) (IEC/EN 60068-2-30)		95 % without condensation		
Vibration (sinusoidal) (IEC/EN 60068-2-6)		10-500 Hz, 2G, each along X, Y, Z axes 6 min / cycle		
Shock (half-sine) (IEC/EN 60068-2-27)		15G, 11 ms, 3 axes, 6 Faces, 3 times for each face		
Isolation data				
Rated insulation voltage U_i	input circuit / output circuit	3 kV AC		
	input / PE	1.5 kV AC		
	output / PE	0.5 kV AC; 0.71 kV DC		
Pollution degree		2		
Standards				
Product standard		EN 61204-3		
Low Voltage Directive		2006/95/EC		
EMC directive		2004/108/EC		
RoHS directive		2002/95/EC		
Electrical safety		EN 60950-1, UL 60950-1, UL 508, EN 61558-1, EN 61558-2-17; EN 60204-1		
Protective low voltage		SELV		
Electromagnetic compatibility				
Interference immunity to		IEC/EN 61000-6-2		
electrostatic discharge	IEC/EN 61000-4-2	Level 4 (air discharge 15 kV / contact discharge 8 kV)		
radiated, radio-frequency, electromagnetic field	IEC/EN 61000-4-3	Level 3 (10 V/m)		
electrical fast transient/burst	IEC/EN 61000-4-4	Level 4 (4 kV / 5 kHz)		
surge	IEC/EN 61000-4-5	L-L Level 3 (2 kV) / L-PE Level 4 (4 kV)		
conducted disturbances, induced by radio-frequency fields	IEC/EN 61000-4-6	Level 3 (10 V)		
power frequency magnetic fields	IEC/EN 61000-4-8	Level 4 (30 A/m)		
voltage dips, short interruptions and voltage variations	IEC/EN 61000-4-11	dips: >95 % 0.5 ms / >30 % 0.5 ms interruptions: >95 % 250 ms IEC/EN 61000-6-3		
Interference emission		IEC/EN 61000-6-3		
high-frequency radiated	IEC/CISPR 22, EN 55022	Class B		
high-frequency conducted	IEC/CISPR 22, EN 55022	Class B		
limits for harmonic current emissions	IEC/EN 61000-3-2	Class A		

„Approvals and marks“ on page 3/4.

CP-T range

Technical diagrams, Dimensional drawings

Technical diagrams

Output curve at $T_j = 25^\circ\text{C}$

dimensions in mm

3

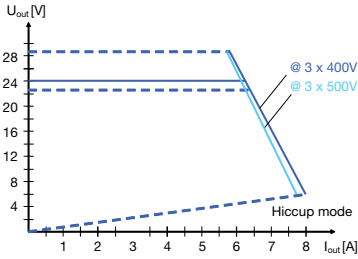

CP-T 24/5.0

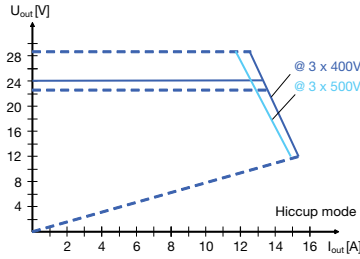

CP-T 24/10.0

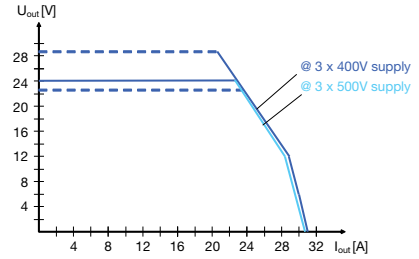

CP-T 24/20.0 U/I curve

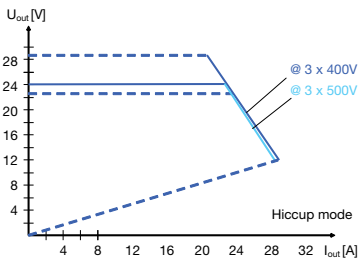

CP-T 24/20.0 Hiccup mode

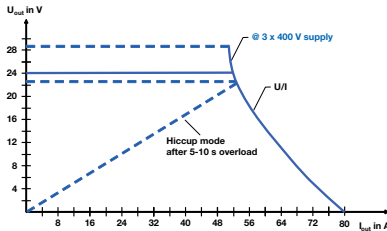

CP-T 24/40.0

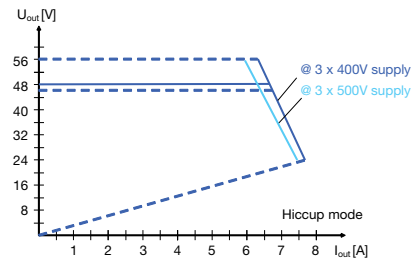

CP-T 48/5.0

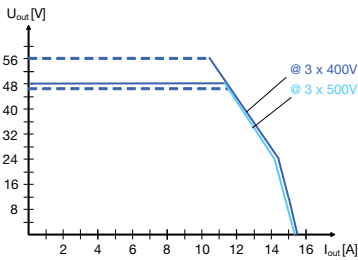

CP-T 48/10.0 U/I curve

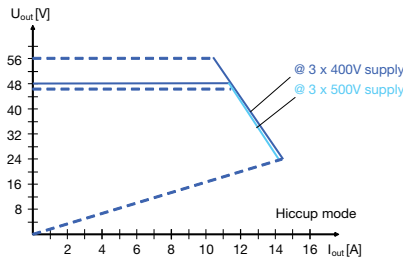

CP-T 48/10.0 Hiccup mode

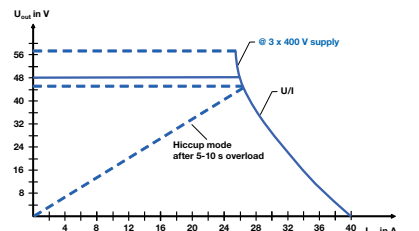

CP-T 48/20.0

Dimensional drawings

dimensions in mm

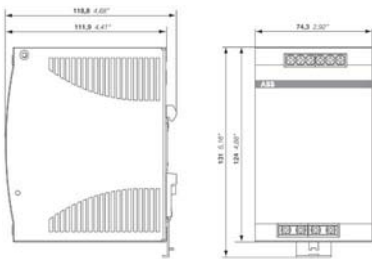

CP-T 24/5.0

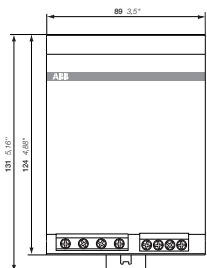

CP-T 24/10.0, CP-T 48/5.0

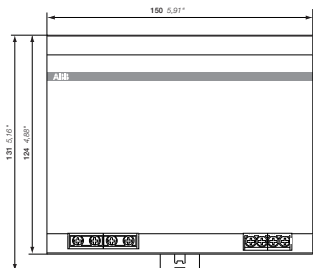

CP-T 24/20.0, CP-T 48/10.0

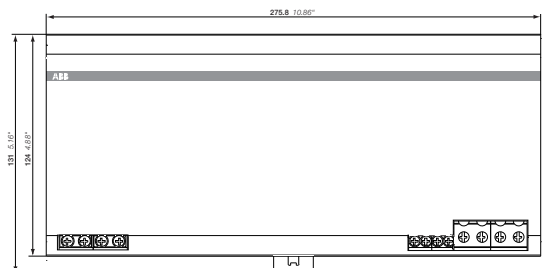

CP-T 24/40.0, CP-T 48/20.0

CP-T range

Technical diagrams

Temperature curve at rated load

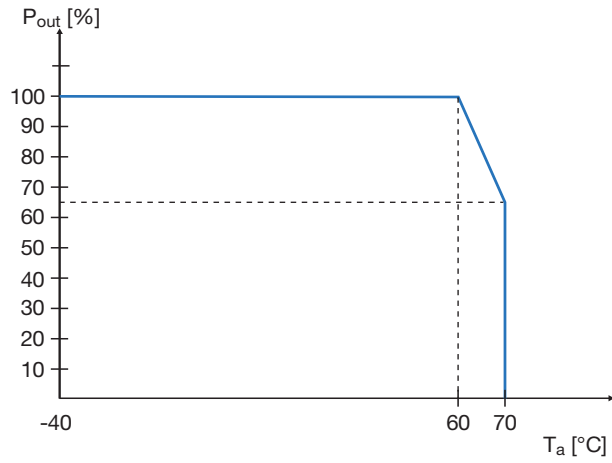

CP-T 24/40.0, CP-T 48/20.0

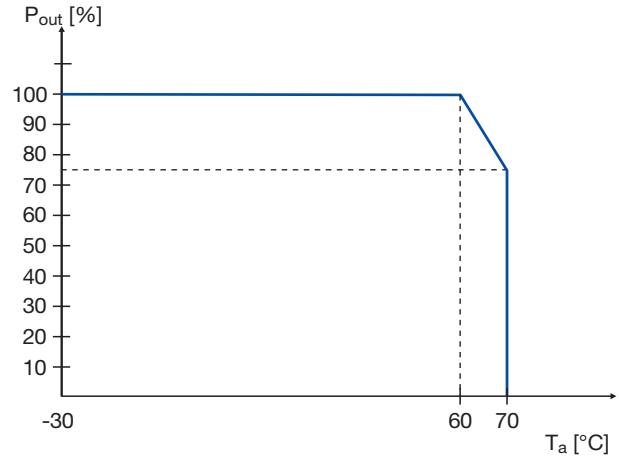

CP-T 24/20.0, CP-T 48/10.0

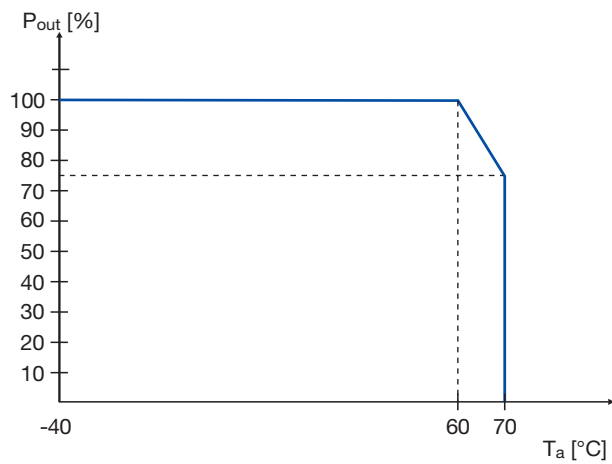

CP-T 24/5.0, CP-T 24/10.0, CP-T 48/5.0

CP-S and CP-C

Product group picture

3



CP-S and CP-C

Table of contents

CP-S and CP-C range	
Product group picture	3/41
Table of contents	3/42
Benefits and advantages	3/43
Operating control	3/44
Ordering details	3/45
Technical data	3/46
Technical diagrams, Dimensional drawings	3/50

CP-S and CP-C

Benefits and advantages

Characteristics

CP-S and CP-C range

- Output current 5 A, 10 A and 20 A
- Integrated power reserve of up to 50 %
- 5 A and 10 A devices with pluggable connecting terminals
- Approvals / marks (depending on device, partly pending)



CP-S range

- 10 A and 20 A device with front-face selector switch to adjust rated input voltage range: 110-120 V AC or 220-240 V AC
- Output voltage fixed at 24 V DC
- Parallel operation for redundancy

CP-C range

- Wide range input 110-240 V AC (85-264 V AC, 100-350 V DC)
- Output voltage adjustable within a range of 22-28 V DC
- Parallel operation for increased capacity and redundancy
- Power factor correction (PFC) acc. to EN 61000-3-2
- Function module pluggable onto the front side

Messaging module CP-C MM:

- LED for status indication
- Relay outputs "Input OK" and "Output OK"
- REMOTE ON/OFF function to switch on and off the power supply externally
- Output voltage monitoring is only possible in decoupled parallel operation

Benefits

Integrated power reserve ①

The new CP-S and CP-C range power supplies feature an integrated power reserve of up to 50 %. No oversized electricity supply is needed, especially under heavy load conditions.

Pluggable connecting terminals ②

Extended flexibility in operation due to pluggable connecting terminals (this feature is not offered on all devices).

Adjustable output voltage ③

The CP-C range types feature a continuously adjustable output voltage from 22 to 28 V. Thus, they can be optimally adapted to the application, e.g. compensating the voltage drop caused by long line length.

Pluggable function modules ④

The CP-C range power supplies can be equipped with pluggable modules to add additional functions (e.g. messaging module). Thus, the power supplies can be ideally adapted to the relevant application.



2CDC 273 056 F0004

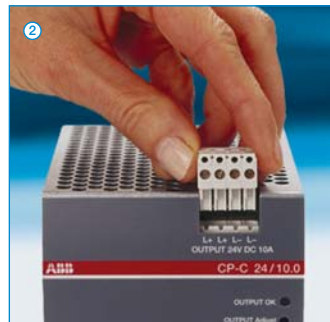

2CDC 273 057 F0004



2CDC 273 046 F0004



2CDC 273 058 F0004

CP-S and CP-C Operating control



- 1** OUTPUT L+, L-: terminals - output
- 2** Indication of operational states
OUTPUT OK: green LED - output voltage OK
- 3** OUTPUT Adj.: rotary potentiometer - adjustment of output voltage
- 4** Circuit diagram
- 5** INPUT L, N, PE: terminals - input

3

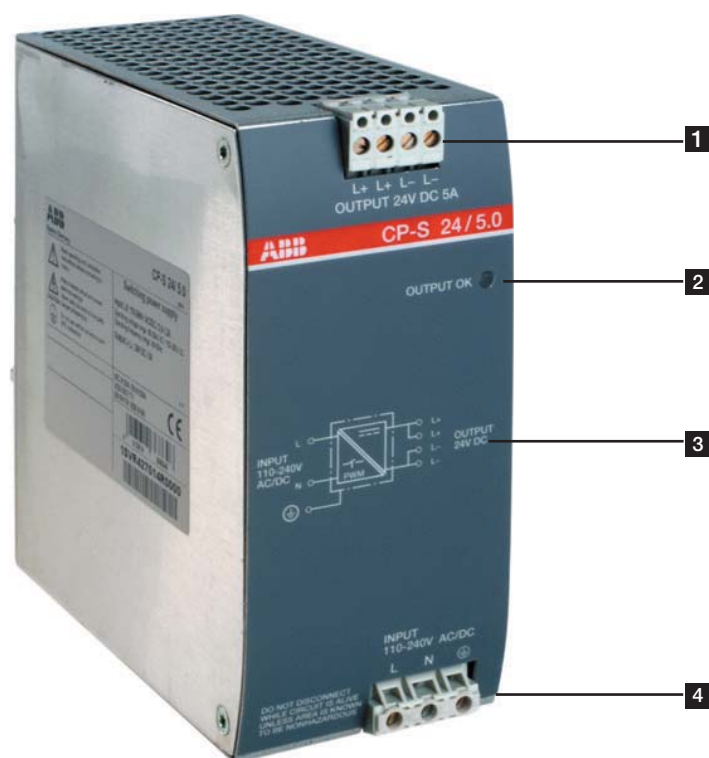

- 1** OUTPUT L+, L-: terminals - output
- 2** Indication of operational states
OUTPUT OK: green LED - output voltage OK
- 3** Circuit diagram
- 4** INPUT L, N, PE: terminals - input

CP-S and CP-C

Ordering details

3



2CDC 271 061 F0004

CP-S 24/5.0



2CDC 271 063 F0004

CP-S 24/20.0



2CDC 271 065 F0004

CP-C 24/10.0

Description

The power supply units in the CP-S and CP-C range are ABB's high-end solutions. Designed with an integrated 50 % power reserve and an efficiency of approximately 89 % these are the perfect products for all complex, highly reliable applications. All the devices cover the U-I output characteristic and are built with thermal protection which switches off in case of overheating. In particular, the devices of the CP-C range feature a much broader functionality, including active power factor correction and pluggable function modules.

These products are designed to trip MCB's in the 24VDC output circuit. Coordination tables are available.

Ordering details - CP-S

Input voltage range	Rated output voltage / current	Type	Order code	Price 1 pce	Weight (1 pce) kg (lb)
85-264 V AC / 110-350 V DC	24 V DC / 5 A	CP-S 24/5.0	1SVR427014R0000		0.96 (2.11)
85-132 V AC, 184-264 V AC / 220-350 V DC	24 V DC / 10 A	CP-S 24/10.0	1SVR427015R0100		1.07 (2.35)
85-132 V AC, 184-264 V AC / 220-350 V DC	24 V DC / 20 A	CP-S 24/20.0	1SVR427016R0100		2.83 (6.23)

Ordering details - CP-C

Input voltage range	Rated output voltage / current	Type	Order code	Price 1 pce	Weight (1 pce) kg (lb)
85-264 V AC / 110-350 V DC	24 V DC / 5 A	CP-C 24/5.0	1SVR427024R0000		0.96 (2.11)
85-264 V AC / 110-350 V DC	24 V DC / 10 A	CP-C 24/10.0	1SVR427025R0000		1.34 (2.95)
85-264 V AC / 110-350 V DC	24 V DC / 20 A	CP-C 24/20.0	1SVR427026R0000		3.15 (6.94)

Description	Type	Order code	Price 1 pce	Weight (1 pce) kg (lb)
Messaging module for CP-C range power supplies	CP-C MM	1SVR427081R0000		0.065 (0.14)

CP-S and CP-C

Technical data

Data at $T_a = 25\text{ °C}$, $U_{in} = 230\text{ V AC}$ and rated values, unless otherwise indicated

Type		CP-C 24/5.0 CP-S 24/5.0	CP-C 24/10.0 CP-S 24/10.0	CP-C 24/20.0 CP-S 24/20.0
Input circuit - supply circuit		L, N		
Rated input voltage U_{in}	CP-C	110-240 V AC		
	CP-S	switch position 115 switch position 230	110-240 V AC	110-120 V AC 220-240 V AC
Input voltage range	CP-C	85-264 V AC / 100-350 V DC ¹⁾		
	CP-S	switch position 115 switch position 230	85-264 V AC / 100-350 V DC ¹⁾	85-132 V AC 184-264 V AC / 220-350 V DC ¹⁾
Frequency range AC		47-63 Hz		
Typical input current	CP-S and CP-C at 110-240 V AC	2.2-1.2 A	2.6-1.2 A	5.5-2.5 A
	CP-S at 110-120 V AC	-	4.2-4.0 A	9.0-8.0 A
	CP-S at 220-240 V AC	-	2.4-2.2 A	4.5-4.0 A
Typ. power consumption		135 W	269 W	538 W
Inrush current limiting / I ² t (cold start)	CP-C	< 23 A / approx. 0.9 A ² s	< 33 A / approx. 0.2 A ² s	< 40 A / approx. 1.9 A ² s
	CP-S		< 40 A / approx. 1.8 A ² s	< 70 A / approx. 8 A ² s
Power failure buffering time		min. 100 ms	min. 40 ms	min. 40 ms
Transient overvoltage protection		varistors		
Internal input fuse (apparatus protection, not accessible)		4 A (slow-acting)	6.3 A (slow-acting)	12 A (fast-acting)
Power factor correction (PFC)	CP-C	yes, active		
	CP-S	no		
Indication of operational states				
Output voltage	OUTPUT OK: green LED	┌───┐ L: output voltage OK		
Output circuit		L+, L+, L-, L- : short-circuit, no-load and overload proof		
Rated output voltage		24 V DC		
Tolerance of the output voltage	CP-C	±1 %		
	CP-S	-1...+5 %		
Adjustment range of the output voltage	CP-C	22-28 V DC, default setting 24 V ±0.5 %		
	CP-S	fixed		
Rated output power		120 W	240 W	480 W
Rated output current		5 A	10 A	20 A
Peak output current (power reserve)	$T_a \leq 60\text{ °C}$	typ. ≤ 7.25 A	typ. ≤ 12.25 A	typ. ≤ 22.5 A
	$T_a \leq 40\text{ °C}$			
Derating	$60\text{ °C} < T_a \leq 70\text{ °C}$	2.5 % per Kelvin temperature increase		
Deviation with	CP-C	load change statical 10-90 %	typ. < ±0.05 %	
	CP-S	load change statical 10-90 %	typ. < ±0.1 %	
		load change dynamical 10-90 %	typ. < ±3 %	
		change of the input voltage of ±10 %	typ. < ±0.05 %	
Control time		typ. < 1 ms		
Starting time after applying supply voltage	CP-C	< 200 ms	< 200 ms	typ. < 200 ms
	CP-S		< 250 ms	typ. < 300 ms
Rise time 10-90 %	CP-C	typ. < 30 ms	typ. < 4 ms	typ. < 12 ms
	CP-S		typ. < 5 ms	typ. < 15 ms
Residual ripple and switching peaks	BW = 20 MHz	typ. < 50 mV _{pp}		
Parallel connection		yes, up to 5 devices, to enable redundancy and to increase power, current not symmetrical (CP-S only redundancy)		
Series connection		yes, to increase voltage, for decoupling refer to the application manual		
Resistance to reverse feed		approx. 35 V DC		
Output circuit - No-load, overload and short-circuit behaviour		see also U/I- and I/T-characteristic curves		
Characteristic curve of output		U/I characteristic curve with power reserve		
Current limiting at short circuit		approx. 11 A	approx. 19 A	approx. 25 A
Short-circuit protection		continuous short-circuit stability		
Overload protection		thermal protection		
Starting of capacitive loads		unlimited		
General data				
Power dissipation		typ. < 15 W	typ. < 29 W	typ. < 58 W
Efficiency		typ. 89 %		
Discharge current for PE		< 3.5 mA		
MTBF	CP-C	500.000 h		
	CP-S	350.000 h		
Dimensions (W x H x D)		56.5 (60 ²⁾ x 130 x 135.5 mm (2.22 (2.36 ²⁾ x 5.12 x 5.35 in)	90 (93.5 ²⁾ x 130 x 135.5 mm (3.54 (3.68 ²⁾ x 5.12 x 5.35 in)	200 (203.5 ²⁾ x 130 x 135.5 mm (7.87 (8.01 ²⁾ x 5.12 x 5.35 in)
Weight	CP-C	approx. 0.96 kg (2.12 lb)	approx. 1.34 kg (2.95 lb)	approx. 3.15 kg (6.94 lb)
	CP-S		approx. 1.07 kg (2.36 lb)	approx. 2.83 kg (6.23 lb)
Minimum distance to other units	horizontal / vertical	10 mm / 80 mm (0.39 in / 3.15 in)		
Degree of protection	housing / terminals	IP20 / IP20		
Material of housing	housing shell / cover	aluminium / zinc-coated sheet steel		
Protection class (EN 61140)		I		
Mounting		DIN rail (IEC/EN 60715), snap-on mounting		
Mounting position		horizontal		

CP-S and CP-C

Technical data

Data at $T_a = 25\text{ °C}$, $U_{in} = 230\text{ V AC}$ and rated values, unless otherwise indicated

Type		CP-C 24/5.0 CP-S 24/5.0 ³⁾	CP-C 24/10.0 CP-S 24/10.0 ³⁾	CP-C 24/20.0 CP-S 24/20.0
Electrical connection - Input circuit				
Wire size	fine-strand with wire end ferrule	0.2-2.5 mm ² (24-14 AWG)		2.5-10 mm ² (14-8 AWG)
	fine-strand without wire end ferrule			0.5-10 mm ² (20-8 AWG)
	rigid			0.5-16 mm ² (20-6 AWG)
Stripping length		7 mm (0.28 in)		12 mm (0.47 in)
Tightening torque		0.4 Nm		1.2-1.5 Nm
Electrical connection - Output circuit				
Wire size	fine-strand with wire end ferrule	0.12-2.5 mm ² (26-14 AWG)		2.5-10 mm ² (14-8 AWG)
	fine-strand without wire end ferrule			0.5-10 mm ² (20-8 AWG)
	rigid			0.5-16 mm ² (20-6 AWG)
Stripping length		8 mm (0.31 in)		12 mm (0.47 in)
Tightening torque		0.4 Nm		1.2-1.5 Nm
Environmental data				
Ambient temperature range	operation	-25...+70 °C		
	rated load	0...+60 °C (without derating)		
	storage	-40...+85 °C		
Damp heat (IEC/EN 60068-2-3)		93 % at +40 °C, no condensation		
Climatic category (IEC/EN 60721)		3K3		
Vibration (IEC/EN 60068-2-6)				
Shock (IEC/EN 60068-2-27)				
Isolation data				
Rated insulation voltage U_i between all isolated circuits (IEC/EN 60950-1; EN 50178)	input / output	300 V		
	input / PE	300 V		
	output / PE	50 V		
Rated impulse withstand voltage U_{imp} between all isolated circuits (IEC/EN 60950-1; EN 50178)	input / output	4 kV; 1.2/50 μ s		
	input / PE	2.5 kV; 1.2/50 μ s		
	output / PE	500 V; 1.2/50 μ s		
Power-frequency withstand voltage test (test voltage) (routine test / type test)	input / output	1.5 kV AC / 3.0 kV AC		
	input / PE	1.5 kV AC / 3.0 kV AC		
	output / PE	500 V DC / 500 V DC		
Pollution degree (IEC/EN 60950-1; EN 50178)		2		
Overvoltage category (IEC/EN 60950-1; EN 50178)		II		
Standards				
Product standard		IEC/EN 61204		
Low Voltage Directive		2006/95/EC		
EMC Directive		2004/108/EC		
Electrical safety		EN 50178, EN 60950, UL 60950, UL 508		
Protective low voltage		SELV (EN 60950)		
Electromagnetic compatibility				
Interference immunity to		IEC/EN 61000-6-2		
electrostatic discharge	IEC/EN 61000-4-2	Level 4 (8 kV / 15 kV)		
radiated, radio-frequency, electromagnetic field	IEC/EN 61000-4-3	Level 3 (10 V/m)		
electrical fast transient / burst	IEC/EN 61000-4-4	Level 4 (4 kV)		
surge	IEC/EN 61000-4-5	Level 4 (2 kV symmetrical, level 3 - 3 kV asymmetrical)		
conducted disturbances, induced by radio-frequency fields	IEC/EN 61000-4-6	Level 3 (10 V)		
Interference emission		IEC/EN 61000-6-3		
high-frequency radiated	IEC/CISPR 22; EN 55022	Class B		
high-frequency conducted	IEC/CISPR 22; EN 55022	Class B		

¹⁾ at $U > 264\text{ V}$ use additionally an appropriate external fuse

²⁾ with lateral screw



³⁾ pluggable connecting terminals, actuate only when power is off

„Approvals and marks“ on page 3/4.

CP-S and CP-C

Technical data

Data at $T_a = 25\text{ °C}$, $U_n = 230\text{ V AC}$ and rated values, unless otherwise indicated

Type	CP-C MM	
Input circuit - Supply circuit		
Rated input voltage U_n	110-240 V AC / 100-350 V DC	
Input voltage range	70-264 V AC / 80-350 V DC	
Power consumption	2.5 VA / 1.5 W	
Input circuit - Control circuit		
Kind of triggering	volt-free triggering	
Control input, control function	Remote OFF	remote off
Threshold "Switching-off power supply unit"	$R \leq 1\text{ k}\Omega$	
Threshold "Switching-on power supply unit"	$R \geq 10\text{ k}\Omega$	
Input current	typ. 1 mA (200 mA for 200 μ s)	
Maximum cable length to the control input	25 m - 100 pF/m	
Measuring circuit - INPUT		
powered by the input circuit of the power supply unit		
Monitoring function	undervoltage monitoring of input voltage of the power supply unit	
Thresholds	85 V AC / 90 V DC	
Hysteresis, related to the threshold value	AC: typ. -8 % / DC -30 %	
Accuracy, tolerance	-5 % at AC and DC	
Maximum measuring cycle	typ. < 50 ms	
Measuring circuit - OUTPUT		
powered by the output circuit of the power supply unit		
Monitoring function	undervoltage monitoring of output voltage of the power supply unit	
Thresholds	20 V DC	
Hysteresis, related to the threshold value	typ. 5 %	
Accuracy, tolerance	$\pm 1\%$	
Maximum measuring cycle	typ. < 10 ms	
Indication of operational states		
Remote off	REMOTE OFF: green LED	 : „REMOTE OFF“ input $R \leq 1\text{ k}\Omega$
Status of power supply input	Input OK: green LED	 : relay „INPUT OK“ energized
Status of power supply output	OUTPUT OK: green LED	 : relay „OUTPUT OK“ energized
Output circuits		
11-12/14, 21-22/24		
Kind of output	relays, 2 x 1 c/o contacts	
Operating principle	closed-circuit principle	
Contact material	AgNi	
Rated voltage (VDE 0110, IEC/EN 60947-1)	250 V	
Minimum switching voltage / Minimum switching current	24 V / 10 mA	
Maximum switching voltage / Maximum switching current	250 V / 1 A	
Rated operating current I_o (IEC/EN 60947-1)	AC12 (resistive) at 230 V	1 A
	AC15 (inductive) at 230 V	1 A
	DC12 (resistive) at 24 V	1 A
	DC13 (inductive) at 24 V	1 A
Mechanical lifetime	30 x 10 ⁶ switching cycles	
Electrical lifetime	0.1 x 10 ⁶ switching cycles	
Short circuit proof, maximum fuse rating	n/c contact	2 A, gL
	n/o contact	2 A, gL
General data		
Duty time	100 %	
Dimensions (W x H x D, when mounted)	56.5 x 54 x 24 mm (2.22 x 2.13 x 0.94 in)	
Weight	0.065 kg (0.14 lb)	
Degree of protection	housing / terminals	IP20 / IP20
Material of housing	Plastic	
Protection class (EN 61140)	II	
Mounting	snap-on mounting, without any tool	
Mounting position	plugged onto the power supply unit	
Electrical connection		
Wire size	fine-strand with wire end ferrule	0.2-2.5 mm ² (24-14 AWG)
	fine-strand without wire end ferrule	
	rigid	0.2-4 mm ² (24-12 AWG)
Stripping length	7.5 mm (0.3 inch)	
Tightening torque	0.4-0.6 Nm	

CP-S and CP-C

Technical data

Data at $T_a = 25\text{ °C}$, $U_{in} = 230\text{ V AC}$ and rated values, unless otherwise indicated

Type	CP-C MM	
Environmental data		
Ambient temperature range	operation	-25...+70 °C
	storage	-40...+85 °C
Damp heat (IEC/EN 60068-2-3)		93 % at +40 °C, no condensation
Climatic category (IEC/EN 60721)		3K3
Vibration (IEC/EN 60068-2-6)		
Shock (IEC/EN 60068-2-27)		
Isolation data		
Rated insulation voltage U_i (IEC/EN 60974-1, EN 50178, VDE 0160)		250 V
Protective separation (EN 50178, EN 60950) supply / measuring circuits / relay outputs		yes
Rated impulse withstand voltage U_{imp} between all isolated circuits (IEC 664, VDE 0110)		4 kV; 1.2/50 μ s
Test voltage between all circuits (type test)		2.5 kV AC
Pollution degree (EN 60950)		2
Overvoltage category (EN 60950)		II
Standards		
Product standard		IEC/EN 61204
Low Voltage Directive		2006/95/EC
EMC Directive		2004/108/EC
Electrical safety		EN 50178, EN 60950, UL 60950, UL 508
Elektromagnetic compatibility		
Interference immunity to		IEC/EN 61000-6-2
electrostatic discharge	IEC/EN 61000-4-2	Level 3 and 4 (6 kV / 8 kV)
radiated, radio-frequency, electromagnetic field	IEC/EN 61000-4-3	Level 3 (10 V/m)
electrical fast transient / burst	IEC/EN 61000-4-4	Level 4 and 2 (4 kV power input / 1 kV control input)
surge	IEC/EN 61000-4-5	Level 3 and 2 (4 kV symmetrical power input / 1 kV control input)
conducted disturbances, induced by radio-frequency fields	IEC/EN 61000-4-6	Level (10 V)
Interference emission		IEC/EN 61000-6-3
high-frequency radiated	IEC/CISPR 22; EN 55022	Class B
high-frequency conducted	IEC/CISPR 22; EN 55022	Class B

„Approvals and marks“ on page 3/4.

CP-S and CP-C

Technical diagrams, Dimensional drawings

Technical diagrams

Output curve at 25 °C

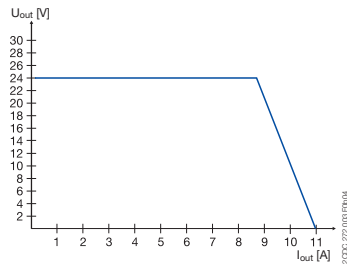

CP-S 24/5.0

Output curve at 25 °C

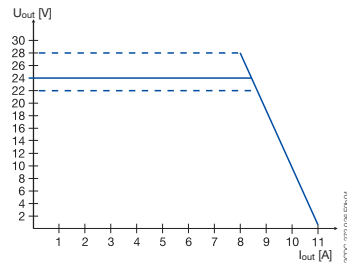

CP-C 24/5.0

Temperature curve at $U_{out} = 24\text{ V DC}$

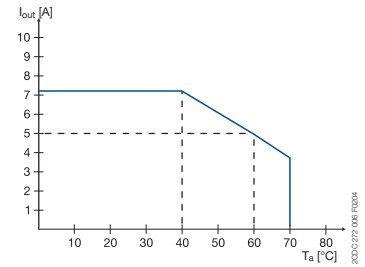

CP-S 24/5.0, CP-C 24/5.0

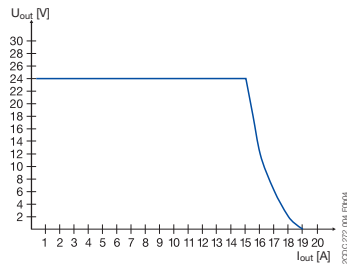

CP-S 24/10.0

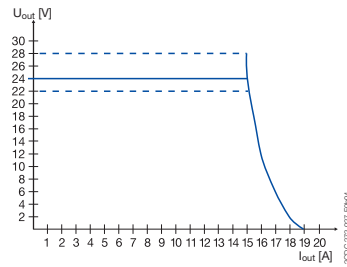

CP-C 24/10.0

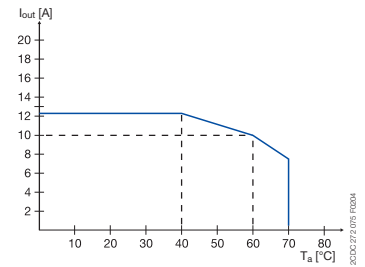

CP-S 24/10.0, CP-C 24/10.0

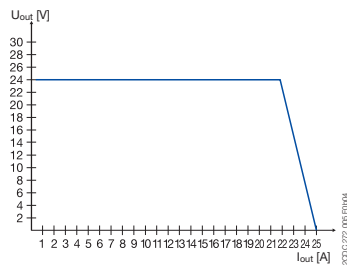

CP-S 24/20.0

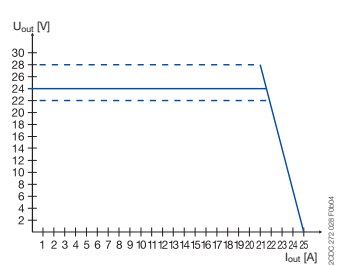

CP-C 24/20.0

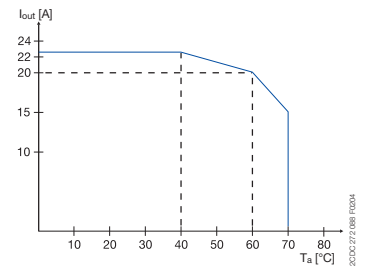

CP-S 24/20.0, CP-C 24/20.0

Dimensional drawings

dimensions in mm

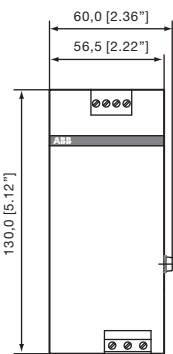
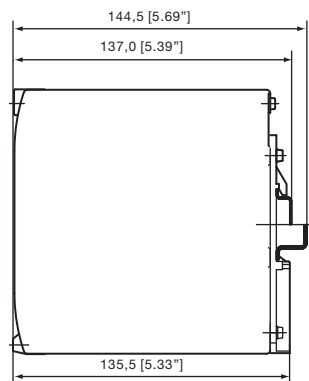

CP-S 24/5.0
CP-C 24/5.0
CP-A RU

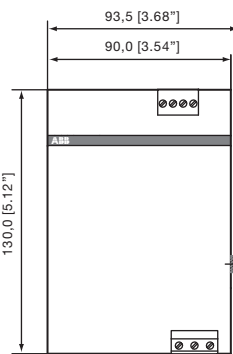

CP-S 24/10.0
CP-C 24/10.0

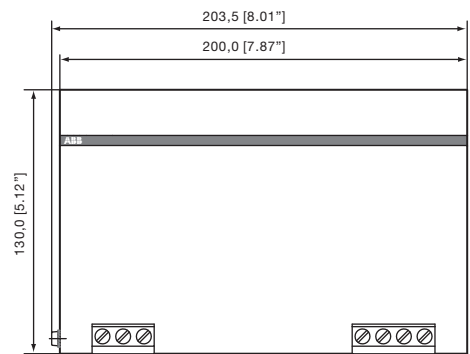

CP-S 24/20.0
CP-C 24/20.0

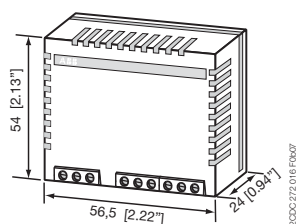

CP-C MM

Redundancy units

Ordering details

3



2CDC 271 003 F0005

CP-A RU + CP-A CM



2CDC 271 010 F0006

CP-A RU



2CDC 271 008 F0003

CP-RUD



2CDC 271 010 F0006

CP-D RU

Ordering details

Description	suitable for decoupling of two CP-24 V DC power supply units or suitable for decoupling of CP-E power supply units	Type	Order code	Price 1 pce	Weight (1 pce) kg (lb)
2 inputs each up to 20 A and 1 output up to 40 A	≤ 40 V and ≥ 5 A	CP-A RU	1SVR427071R0000		0.89 (1.96)
Control module for CP-A RU redundancy units	-	CP-A CM	1SVR427075R0000		0.063 (0.14)
2 inputs each up to 2.5 A and 1 output up to 5 A	≤ 35 V and < 5 A	CP-RUD	1SVR423418R9000		0.15 (0.33)

Ordering details - CP-D RU for decoupling of two CP-D power supply units

Input voltage range	Rated input current	Rated output voltage / current	Type	Order code	Price	Weight (1 pce) kg (lb)
9-35 V DC	2 x 5 A	24 V DC / 1 x 10 A	CP-D RU	1SVR427049R0000		0.075 (0.165)

Redundancy units

Technical data

Type	CP-A RU		CP-A RU in combination with CP-A CM
Input circuit - Supply circuit	(+/-, +/-)		
Rated input voltage U_{in}	24 V DC		
Input voltage range per channel	10-28 V DC	13-28 V DC	
Rated input current I_{in} per channel	1-20 A		
Maximum input current per channel	30 A for 300 s		
Transient overvoltage protection	yes		
Output circuit	(++/--)		
Rated output voltage U_{out}	24 V DC		
Voltage drop	typ. 0.6 V, max. 0.9 V		
Rated output current I_{out}	1-40 A		
Output ratings per channel	$T_a = 60\text{ °C}$	10-28 V DC / 40 A	13-28 V DC / 40 A
	$T_a = 70\text{ °C}$	10-28 V DC / 30 A	13-28 V DC / 30 A
Derating	$60\text{ °C} < T_a \leq 70\text{ °C}$	2.5 % per Kelvin temperature increase	
Peak output current	60 A for 300 s		
Resistance to reverse feed	< 40 V		
General data			
Dimensions (W x H x D)	56.5 (60 ¹⁾) x 130 x 135.5 mm; (2.22 (2.36 ¹⁾) x 5.12 x 5.35 in)		
Weight	0.89 kg (1.96 lb)		
Minimum distance to other units	horizontal / vertical	10 mm / 50 mm (0.39 in / 1.97 in)	
Degree of protection	housing / terminals	IP20 / IP20	
Material of housing	housing shell / cover	aluminium / zinc-coated sheet steel	
Protection class	III ²⁾		
Mounting	DIN rail (IEC/EN 60715)		
Mounting position	horizontal		
Electrical connection - Input circuit / Output circuit			
Wire size	fine-strand with wire end ferrule	2.5-10 mm ² (14-8 AWG)	
	fine-strand without wire end ferrule	0.5-10 mm ² (20-8 AWG)	
	rigid	0.5-16 mm ² (20-6 AWG)	
Stripping length	12 mm (0.47 in)		
Tightening torque	1.2-1.5 Nm		
Environmental data			
Ambient temperature range	operation	-25...+70 °C	
	rated load	-25...+60 °C (without derating)	
	storage	-40...+85 °C	
Damp heat (IEC/EN 60068-2-3)	93 % at 40 °C, no condensation		
Climatic category (IEC/EN 60721)	3K3		
Vibration (IEC/EN 60068-2-6)			
Shock (IEC/EN 60068-2-27)			
Isolation data			
Insulation voltage	between input / output / housing	500 V AC (routine test)	
Pollution degree (EN 50178)	2		
Standards			
Product standard	IEC/EN 61204		
Low Voltage Directive	2006/95/EC		
EMC Directive	2004/108/EC		
Electrical safety	EN 50178, EN 60950, UL 60950, UL 508		
Electromagnetic compatibility			
Interference immunity to	IEC/EN 61000-6-2		
electrostatic discharge	IEC/EN 61000-4-2	Level 3 (air discharge ±8 kV, contact discharge ±6 kV)	
radiated, radio-frequency, electromagnetic field	IEC/EN 61000-4-3	Level 3 (10 V/m)	
electrical fast transient / burst	IEC/EN 61000-4-4	Level 3 (±2 kV)	
surge	IEC/EN 61000-4-5	Level 1 (±0.5 kV)	
conducted disturbances, induced by radio-frequency fields	IEC/EN 61000-4-6	Level 3 (10 V)	
Interference emission	IEC/EN 61000-6-3		
high-frequency radiated	IEC/CISPR 22 / EN 55022	Class B	
high-frequency conducted	IEC/CISPR 22 / EN 55022	Class B	



¹⁾ incl. lateral screw

²⁾ This device is designed for connection to a safety extra-low voltage source. If no safety extra-low voltage is used at the input side, the lateral screw can be used for grounding of the housing (protection class I).

„Approvals and marks“ on page 3/4.

Redundancy units

Technical data

Type	CP-A CM	
Input circuit - Supply circuit		
Rated input voltage U_n		24 V DC
Input voltage range		13-28 V DC
Rated input current	at rated sense load and 24 V DC	120 mA
Power consumption	at 24 V DC	approx. 1 W
Measuring circuit		
Monitoring function		11-12/14, 21-22/24 undervoltage monitoring
Measuring voltage		rated operational voltage
Thresholds		14-28 V
Hysteresis, related to the threshold value		fix: 3-5 %
Accuracy, tolerance		10 % of full-scale value
Maximum measuring cycle		6 ms
Indication of operational states		
Status of input 1	IN 1: green LED	 L: voltage at input 1 > than threshold 1 = no faults present
Status of input 2	IN 2: green LED	 L: voltage at input 2 > than threshold 2 = no faults present
Output status	OUT: green LED	 L: $U_{OUT} > 3 V$ = no faults present
Output circuit		
Kind of output		relays, 2 x 1 c/o contact
Contact material		AgNi
Operating principle		closed-circuit principle
Rated operational voltage U_n (IEC/EN 60947-1, VDE 0110)		250 V
Minimum switching voltage / Minimum switching current		24 V / 10 mA
Maximum switching voltage / Maximum switching current		250 V / 1 A
Rated operational current I_n (IEC/EN 60947-5-1)	AC12 (resistive) at 230 V	1 A
	AC15 (inductive) at 230 V	1 A
	DC12 (resistive) at 24 V	1 A
	DC13 (inductive) at 24 V	1 A
Mechanical lifetime		30 x 10 ⁶ switching cycles
Electrical lifetime		0.1 x 10 ⁶ switching cycles
Rating according UL 508	General purpose (GP) 250 V AC	1 A
Maximum fuse rating to achieve short-circuit protection	n/o contact	2 A, gL
	n/c contact	2 A, gL
Sense output (+, +, -)		
Sense output voltage		1 SVR 427 075 R0000 13-28 V DC
Sense output current		0.1 A
Maximum fuse rating		For applications acc. UL the sense output shall be provided with a listed DC fuse 3 A
General data		
Duty time		100 %
Dimensions (W x H x D, when mounted)		56.5 x 54 x 24 mm (2.22 x 2.13 x 0.94 in)
Material of housing		plastic
Weight		0.063 kg (0.14 lb)
Degree of protection	housing / terminals	IP20 / IP20
Protection class		II
Mounting		snap-on mounting, without any tool
Mounting position		plugged onto the redundancy unit CP-A RU
Electrical connection		
Wire size	fine-strand with wire end ferrule	0.2-2.5 mm ² (24-14 AWG)
	fine-strand without wire end ferrule	
	rigid	0.2-4 mm ² (24-12 AWG)
Stripping length		7.5 mm (0.3 in)
Tightening torque		0.4-0.6 Nm
Isolation data		
Rated insulation voltage U_n (IEC/EN 60947-1, EN 50178, VDE 0160)		250 V
Rated impulse withstand voltage U_{imp} (type test) between all circuits (IEC 664, VDE 0110)		2.5 kV
Power-frequency withstand voltage test (routine test) between all circuits		1.2 kV AC
Protective separation (EN 50178) between input and output		yes
Pollution degree		2
Overvoltage category		II
Environmental data		
Ambient temperature range	operation	-25...+70 °C
	storage	-40...+85 °C
Damp heat (IEC/EN 60068-2-3)		93 % at 40 °C, no condensation
Climatic category (IEC/EN 60721)		3K3
Vibration (IEC/EN 60068-2-6)		
Shock (IEC/EN 60068-2-27)		

Redundancy units

Technical data

Type	CP-RUD	
Input circuit - Supply circuit	A: U1+/-U ; B: U2+/-U	
Rated input voltage U_{in}	24 V DC	
Input voltage range	5-35 V DC	
Rated input current I_{in} per channel	0.5-2.5 A	
Maximum input current per channel	10 A for 300 s	
Transient overvoltage protection	no	
Output circuit	L+, L+, L+, L-, L-, L-	
Rated output voltage U_{out}	24 V DC	
Voltage drop	typ. 0.6 V, max. 0.7 V	
Rated output current I_{out}	0.5-5 A	
Peak output current	20 A for 150 s	
Resistance to reverse feed	< 35 V	
General data		
Dimensions (W x H x D)	22.5 x 78 x 100 mm (0.89 x 3.07 x 4.02 in)	
Weight	0.135 kg (0.30 lb)	
Minimum distance to other units	horizontal / vertical	10 mm / 10 mm (0.39 in / 0.39 in)
Degree of protection	housing / terminals	IP20 / IP20
Material of housing	housing shell / cover	plastic / plastic
Protection class	-	
Mounting	DIN rail (IEC/EN 60715)	
Mounting position	horizontal	
Electrical connection - Input circuit / Output circuit		
Wire size	fine-strand with wire end ferrule	2 x 0.75-2.5 mm ² (2 x 18-14 AWG)
	fine-strand without wire end ferrule	
	rigid	2 x 0.5-4 mm ² (2 x 20-12 AWG)
Stripping length	7 mm (0.28 in)	
Tightening torque	0.6-0.8 Nm	
Environmental data		
Ambient temperature range	operation	-20...+60 °C
	rated load	-20...+60 °C
	storage	-40...+85 °C
Damp heat (IEC/EN 60068-2-3)	93 % at 40 °C, no condensation	
Climatic category (IEC/EN 60721)	-	
Vibration (IEC/EN 60068-2-6)	-	
Shock (IEC/EN 60068-2-27)	-	
Isolation data		
Insulation voltage	between input / output / housing	-
Pollution degree (EN 50178)	2	
Standards		
Product standard		
Low Voltage Directive	2006/95/EC	
EMC Directive	2004/108/EC	
Electrical safety	EN 50178	
Electromagnetic compatibility		
Interference immunity to	IEC/EN 61000-6-2	
electrostatic discharge	IEC/EN 61000-4-2	Level 3 (air discharge ±8 kV, contact discharge ±6 kV)
radiated, radio-frequency, electromagnetic field	IEC/EN 61000-4-3	Level 3 (10 V/m)
electrical fast transient/burst	IEC/EN 61000-4-4	Level 3 (±2 kV)
surge	IEC/EN 61000-4-5	Level 1 (±0.5 kV)
conducted disturbances, induced by radio-frequency fields	IEC/EN 61000-4-6	Level 3 (10 V)
Interference emission	IEC/EN 61000-6-3	
high-frequency radiated	IEC/CISPR 22 / EN 55022	Class B
high-frequency conducted	IEC/CISPR 22 / EN 55022	Class B

¹⁾ incl. lateral screw

²⁾ This device is designed for connection to a safety extra-low voltage source. If no safety extra-low voltage is used at the input side, the lateral screw can be used for grounding of the housing (protection class I).

Redundancy units

Technical data

3

Type		CP- D RU
Input circuit - Supply circuit		IN 1 + + -, IN 2 + + -
Rated input voltage U_{in}		24 V DC
Input voltage range		9-35 V DC
Rated input current I_{in} per channel		5 A
Maximum input current per channel		10 A for 300 s
Transient overvoltage protection		no
Output circuit		OUT + + +, - - -
Rated output voltage U_{out}		24 V DC
Voltage drop		typ. 0.5 V
Rated output current I_{out}		10 A
Resistance to reverse feed		< 35 V
General data		
MTBF		on request
Duty time		100 %
Dimensions (W x H x D)	product dimensions	35 x 91 x 56.5 mm (1.38 x 3.58 x 2.22 in)
	packaging dimensions	134 x 94 x 48 mm (5.28 x 3.70 x 1.89 in)
Weight	net weight	0.075 kg (0.165 lb)
	gross weight	0.130 kg (0.286 lb)
Material of housing		plastic
Mounting		DIN rail, snap-on mounting without any tool
Mounting position		horizontal
Minimum distance to other units	horizontal / vertical	25 mm (0.98 in) / 25 mm (0.98 in)
Electrical connection - Input circuit / Output circuit		
Wire size	fine-strand with (out)	0.2-2.5 mm ² (24-14 AWG)
	wire end ferrule	
	rigid	0.2-2.5 mm ² (24-12 AWG)
Stripping length		7.0 mm (0.28 in)
Tightening torque		0.67 Nm (6 lb.in)
Environmental data		
Ambient temperature range	operation	-40...+70 °C
	storage	-40...+85 °C
Relative humidity	RH at 40 °C	20-95 %, no condensation
Vibration (IEC/EN 60068-2-6)		Mounting by rail: 10-500 Hz, 2 G, along X, Y, Z each axis, 60 min for each axis
Shock (IEC/EN 60068-2-27)		15 G, 11 ms, 3 axis, 6 faces, 3 times for each face
Standards		
Product standard		IEC/EN 61204-3
Low Voltage Directive		2006/95/EC
EMC Directive		2004/108/EC
RoHS Directive		2002/95/EC
Electromagnetic compatibility		
Interference immunity to		EN 55024
electrostatic discharge	IEC/EN 61000-4-2	Level 3, air discharge 8 kV, contact discharge 4 kV
radiated, radio-frequency, electromagnetic field	IEC/EN 61000-4-3	Level 3, 10 V/m
electrical fast transient/burst	IEC/EN 61000-4-4	Level 3, 2 kV / 5 kHz
conducted disturbances, induced by radio-frequency fields	IEC/EN 61000-4-6	Level 3, 10 V
Interference emission		EN 55022
high-frequency radiated	IEC/CISPR 22 / EN 55022	Class B
high-frequency conducted	IEC/CISPR 22 / EN 55022	Class B

Redundancy units

Dimensional drawings

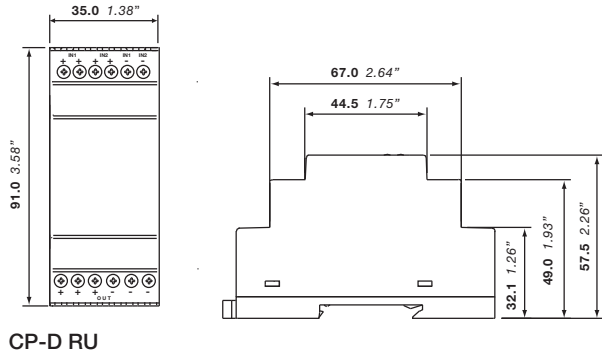

2CDC272033F0010

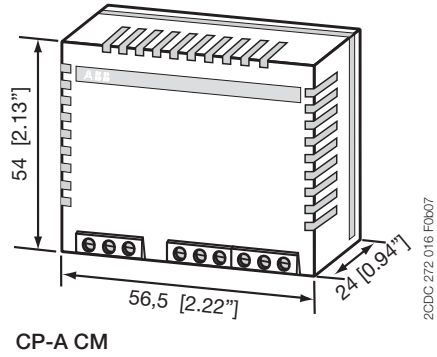

2CDC 272 016 F0b07

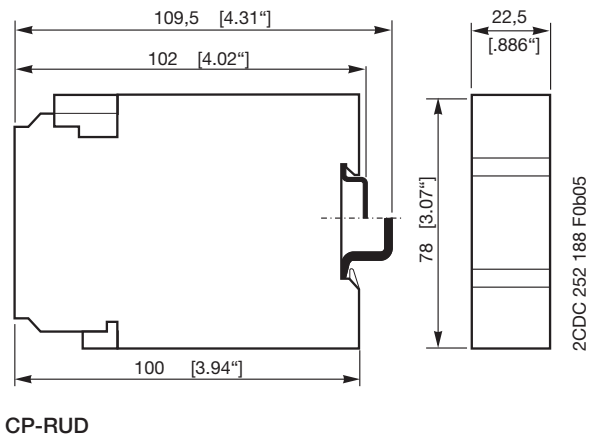

2CDC 252 188 F0b05

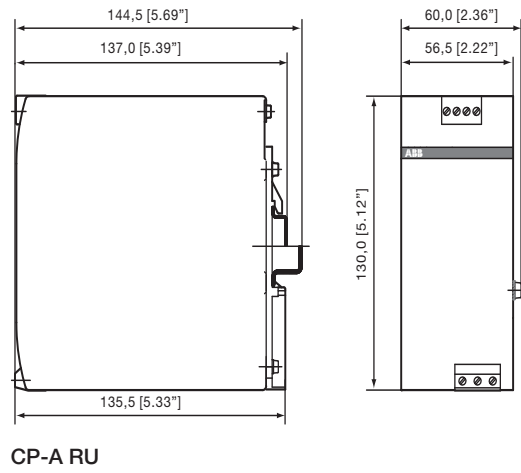

2CDC 272 015 F0b07

CP-ASI range Product group picture

3



CP-ASI range

Table of contents

CP-ASI	
Product group picture	3/57
Table of contents	3/58
Benefits and advantages	3/59
Ordering details	3/60
Technical data	3/61
Technical diagrams	3/63
Dimensional drawings	3/64

CP-ASI range

Benefits and advantages

Characteristics

- Rated output voltage 30.5 V DC for ASI-bus
- Rated output current up to 8.0 A
- High efficiency of up to 92 % ¹⁾
- Infrared addressing mode ²⁾
- Low power dissipation and low heating
- Free convection cooling (no forced cooling with ventilators)
- Ambient temperature range during operation -10...70 °C ³⁾
- Open-circuit, overload and short-circuit stable
- Integrated input fuse
- Tool-free mounting on DIN rail as well as demounting
- LEDs for the indication of operational states

■ Approval:  / Mark: **CE**

¹⁾ Efficiency is depending on device

²⁾ Except CP-ASI/4.0 DC/DC

³⁾ Ambient temperature range CP-ASI/4.0 DC/DC -25...70°C

⁴⁾ Approvals are related to rated input voltage U_{in}

3

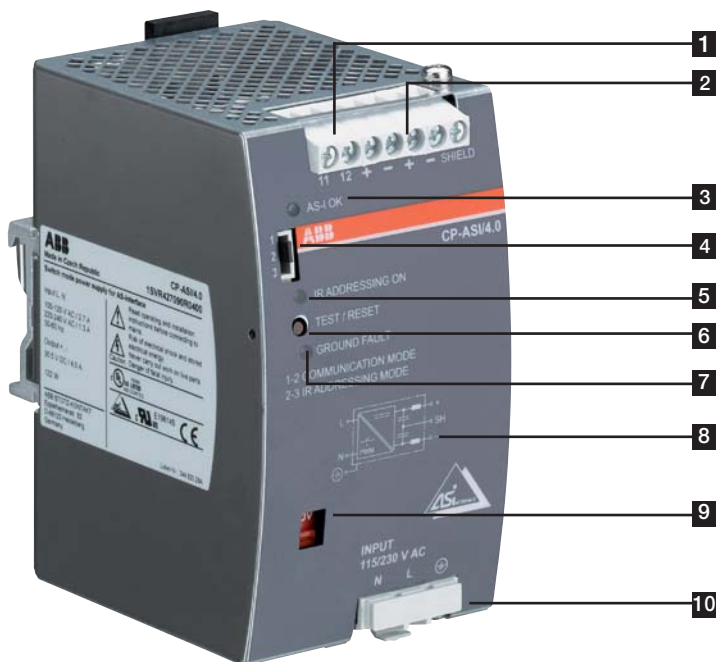

- 1** Output +, -, +, -, SHIELD: output terminals
- 2** Signalling contact 11-12: ground fault signalling terminals
- 3** Indication of operational states
AS-I OK: green LED - output voltage OK
- 4** Configuration of operation mode Jumper
- 5** Indication of operational states
IR ADDRESSING ON: red LED - infrared addressing mode active
- 6** Test and reset button
- 7** Indication of operational states
GROUND FAULT: red LED - ground fault detected
- 8** Circuit diagram
- 9** Input voltage selector Adjustment of input voltage
- 10** Input L, N, PE: input terminals

CP-ASI range

Ordering details



2CDC 271 002 S0012

CP-ASI/2.8



2CDC 271 003 S0012

CP-ASI/4.0 DC/DC



2CDC 271 004 S0012

CP-ASI/4.0



2CDC 271 005 S0012

CP-ASI/8.0

Description

The CP-ASI power supply range is specifically designed with integrated data decoupling for the supply of AS-Interface systems.

Up to 62 slaves (binary I/O devices) can be supplied with a single two-conductor cable.

The configurable IR addressing mode allows the easy assign of new ID addresses by means of an external infrared programming unit.

Ordering details

Input Voltage Range	Rated Output Voltage	Rated Output Current	Type	Order code	Price 1 pce	Weight (1 pce) kg (lb)
85-132 V AC, 184-264 V AC	30.5 V DC	2.8 A	CP-ASI/2.8	1SVR427090R0280		0.495 (1.091)
85-132 V AC, 184-264 V AC	30.5 V DC	4.0 A	CP-ASI/4.0	1SVR427090R0400		0.653 (1.440)
18-32.4 V DC	30.5 V DC	4.0 A	CP-ASI/4.0 DC/DC	1SVR427095R0400		0.488 (1.076)
85-132 V AC, 184-264 V AC	30.5 V DC	8.0 A	CP-ASI/8.0	1SVR427090R0800		0.897 (1.978)

CP-ASI range

Technical data

Data at $T_a = 25\text{ °C}$, $U_{in} = 230\text{ V AC}$ and rated values, unless otherwise indicated

Type	CP-ASI/2.8	CP-ASI/4.0	CP-ASI/8.0	CP-ASI/4.0 DC/DC
Input circuit - Supply circuit	L, N			
Rated input voltage U_{in}	-	-	-	24 V DC
	switch position 115 V	100-120 V AC	-	-
	switch position 230 V	220-240 V AC	-	-
Input voltage range	-	-	-	18.0-32.4 V DC
	switch position 115 V	85-132 V AC	-	-
	switch position 230 V	184-264 V AC	184-264 V AC / 240-300 V DC	184-264 V AC
Frequency range AC	47-63 Hz	-	-	-
Typical input current	-	-	-	5.6 A
	switch position 115 V	2.0 A	2.7 A	6.0 A
	switch position 230 V	0.9 A	1.3 A	2.8 A
Allowed voltage between input and earth (ground)	-	-	-	max. 60 V DC / 42.4 V AC
Allowed input ripple voltage	-	-	-	max. 5 Vpp, 47 Hz - 40 kHz
Continuous input voltage with no damage to the DC/DC converter	-	-	-	max. 36.0 V DC
Turn-on voltage	-	-	-	typ. 17.5 V DC
Shut-down voltage	-	-	-	typ. 14.0 V DC
	-	-	-	typ. 35 V DC
Typical power consumption	94 W	135 W	261 W	132 W
Inrush current limiting / Ft (cold start)	< 20 A (132 V AC) / approx. 1.5 A ² /s < 38 A (264 V AC) / approx. 1.8 A ² /s	< 44.7 A (120 V AC) / approx. 3.7 A ² /s < 49.3 A (132 V AC) / approx. 4.6 A ² /s < 49.7 A (230 V AC) / approx. 2.5 A ² /s < 57.5 A (264 V AC) / approx. 3.3 A ² /s	< 12 A (100 V AC) / approx. 1.0 A ² /s < 14 A (120 V AC) / approx. 1.5 A ² /s < 24 A (220 V AC) / approx. 1.4 A ² /s < 27 A (240 V AC) / approx. 1.6 A ² /s	< 1.8 A / approx. 1.0 A ² /s
Discharge current towards PE	< 3.5 mA	-	-	-
Power failure buffering time	-	-	-	max. 0.5 ms
	at 115 V AC	min. 35 ms	min. 40 ms	min. 20 ms
	at 230 V AC	min. 40 ms	-	min. 30 ms
Transient overvoltage protection	varistors	-	-	-
Reverse input polarity protection	-	-	-	included, unit does not start at reversed polarity
Internal input fuse	8 A slow acting / 250 V AC	3.15 A slow acting / 250 V AC	8 A slow acting / 250 V AC	10 A slow acting
External fusing (not necessary, but recommended)	-	-	-	at 115 V AC
Power factor correction (PFC)	at 115 V AC	0.58	0.53	0.48
	at 230 V AC	0.53	-	-
Indication of operational states				
Output voltage	AS-I OK	LED green	-	-
IR addressing mode	IR ADDRESSING ON	LED red	-	-
Overload	OVERLOAD	LED red	-	-
Output circuit				
Rated output voltage	+,-	30.5 V DC	-	-
Rated output power	-	85 W	122 W	244 W
Tolerance of the output voltage	-	± 3 %	-	-
Adjustment range of the output voltage	-	-	-	-
Rated output current I _o	$T_a \leq 60\text{ °C}$	2.8 A	4.0 A	8.0 A
Derating of the output current	$60\text{ °C} < T_a \leq 70\text{ °C}$	2.5 %/°C	-	-
Signalling contact for ground fault	-	-	max. 25 V AC or 60 V DC, 0.5 A	-
Control time	-	< 2 ms	-	-
Starting time after applying the supply voltage	-	max. 400 ms	max. 700 ms	max. 500 ms
Rise time	-	max. 100 ms	-	max. 1 s (typ. 650 ms)
	at rated load	-	-	typ. 100 ms
	with 5 mF	-	-	typ. 200 ms
Residual ripple	BW = 500 kHz	typ. < 50 mV _{pp}	-	-
Switching peaks	BW = 20 MHz	typ. < 100 mV _{pp}	-	-
Output circuit - No-load, overload and short-circuit behaviour				
Characteristic curve of output	U/I characteristic curve	-	Combined U/I characteristic curve and hiccup mode	U/I characteristic curve
Short-circuit protection	continuous short-circuit stability	-	temporary short-circuit stability	continuous short-circuit stability
Short-circuit behaviour	continuation with output power limiting	-	-	continuation with output power limiting
Current limiting at short circuit	min / max	3.2 A / 4.6 A	4.2 A / 6.5 A	12 A / 25 A (max. 5 s)
Overload protection	output power limiting	-	temporary output power limiting	output power limiting

CP-ASI range

Technical data

Data at $T_a = 25\text{ °C}$, $U_n = 230\text{ V AC}$ and rated values, unless otherwise indicated

Type		CP-ASI/2.8	CP-ASI/4.0	CP-ASI/8.0	CP-ASI/4.0 DC/DC
Overtemperature, overload and short circuit behaviour		CP-ASI/8.0: at 8.4 A < I_{max} < 12 A continuous current for 2-5 s, afterwards safety switch-off			
Overtemperature protection		CP-ASI/4.0 DC/DC: yes, automatic recovery after temperature went down			
No-load protection		continuous no-load stability			
General data					
MTBF		on request			
Power dissipation		typ. < 9.1 W (230 V AC, 2.8 A)	typ. < 13.5 W (230 V AC, 4.0 A)	typ. < 21.2 W (230 V AC, 8.0 A)	typ. < 12.7 W (24 V DC, 4.0 A)
Efficiency		typ. 90.5 %	typ. 90 %	typ. 92.0 %	typ. 90.5 %
Duty time		100 %			
Dimensions (W x H x D)	product dimensions	49 x 131 x 107 mm (1.93 x 5.16 x 4.21 in)	73 x 131 x 107 mm (2.87 x 5.16 x 4.21 in)	91 x 131 x 107 mm (3.58 x 5.16 x 4.21 in)	40 x 131 x 107 mm (1.58 x 5.16 x 4.21 in)
	packaging dimensions	151 x 65 x 140 mm (5.94 x 2.56 x 5.51 in)	151 x 98 x 140 mm (5.94 x 3.86 x 5.51 in)	151 x 120 x 140 mm (5.94 x 4.72 x 5.51 in)	151 x 65 x 140 mm (5.94 x 2.56 x 5.51 in)
Weight	net weight	0.495 kg (1.019 lb)	0.653 kg (1.440 lb)	0.897 kg (1.997 lb)	0.488 kg (1.076 lb)
	gross weight	0.568 kg (1.252 lb)	0.750 kg (1.653 lb)	1.015 kg (2.238 lb)	0.750 kg (1.287 lb)
Material of housing		metal			
Mounting		DIN rail (IEC/EN 60715), snap-on mounting without any tool			
Mounting position		horizontal			
Minimum distance to other units	horizontal / vertical	15 mm / 25 mm (0.59 / 0.99 in)			
Degree of protection	housing / terminals	IP20 / IP20			
Protection class		I			
Electrical connection					
Wire size	fine-strand with wire end ferrule	0.5-4 mm ² (20-12 AWG)			
	fine-strand without wire end ferrule	0.5-4 mm ² (20-12 AWG)			
Stripping length	rigid	0.5-6 mm ² (20-10 AWG)			
		7 mm (0.28 in)			
Tightening torque		0.8 Nm (7.08 lb.in)			
Environmental data					
Ambient temperature range	operation	-10...+70 °C			-25...+70 °C
	rated load	-10...+60 °C			-25...+60 °C
	storage	-25...+85 °C			-40...+85 °C
Vibration (sinusoidal) (IEC/EN 60068-2-6)		2-17.8 Hz, amplitude ± 1.6 mm			
	sinusoidal (IEC/EN 60068-2-6)	17.8 Hz - 500 Hz, 2 g			
	random (IEC 60068-2-64)	2-800 Hz 0.5 s ² (s ³)			
Shock (half-sine) (IEC/EN 60068-2-27)		15 g (6 ms), 10 g (11 ms)			
Isolation data					
Rated insulation voltage U_i (IEC/EN 60950-1, EN 50178)	input circuit / output circuit	300 V			50 V
	input / PE	300 V			50 V
	output / PE	50 V			
	shield / output shield / PE	50 V 50 V			
Rated impulse withstand voltage U_{imp} (EN 50178)	input / output	6 kV 1.2/50 µs			1.5 kV 1.2/50 µs
	input / PE	4 kV 1.2/50 µs			0.8 kV 1.2/50 µs
	output / PE	500 V 1.2/50 µs			500 V 1.2/50 µs
Power-frequency withstand voltage test (test voltage) (routine test / type test)	input / output	2.5 kV AC / 3.0 kV AC			1.5 kV AC / 1.5 kV AC
	input / PE	2.5 kV AC / 2.5 kV AC			1.5 kV AC / 1.5 kV AC
	output / PE	500 V AC / 500 V AC			
Pollution degree (IEC/EN 60950-1)		2			
Overvoltage category (UL/IEC/EN 60950-1)	input	II (IEC/EN 60950-1), III (EN 50178)			
	output	II (IEC/EN 60950-1), II (EN 50178)			
Standards					
Low Voltage Directive		2006/95/EC			
EMC directive		2004/108/EC			
RoHS directive		2011/65/EC			
Electrical safety		IEC/EN 60950-1			
Protective low voltage		SELV (IEC/EN 60950-1), PELV			
Electromagnetic compatibility					
Interference immunity to electrostatic discharge	IEC/EN 61000-4-2	IEC/EN 61000-6-2 Level 4 (8 kV / 15 kV)			
radiated, radio-frequency, electromagnetic field	IEC/EN 61000-4-3	Level 3 (10 V/m)			
electrical fast transient/burst	IEC/EN 61000-4-4	input circuit: Level 4 (4 kV) output circuit: Level 3 (2 kV)			input circuit: Level 3 (2 kV) output circuit: Level 2 (1 kV)
surge	IEC/EN 61000-4-5	input circuit: L-L Level 3 (2 kV) / L-PE Level 4 (4 kV) output circuit: Level 1 (0.5 kV)			input circuit: L-L Level 2 (1 kV) / L-PE Level 3 (2 kV) output circuit: Level 1 (0.5 kV)
conducted disturbances, induced by radio-frequency fields	IEC/EN 61000-4-6	Level 3 (10 V, 150 kHz - 80 MHz)			Level 3 (10 V, 150 kHz - 80 MHz)
voltage dips, short interruptions and voltage variations	IEC/EN 61000-4-11	Class 3			
Interference emission	IEC/EN 61000-6-3	IEC/EN 61000-6-3			IEC/EN 61000-6-3
	high-frequency radiated	IEC/CISPR 22, EN 55022	Class B		
	high-frequency conducted	IEC/CISPR 22, EN 55022	Class B		
	limits for harmonic current emissions	IEC/EN 61000-3-2	Class A		

CP-ASI range

Technical diagrams

Characteristic curve at $T_a = 25\text{ °C}$

CP-ASI 2.8

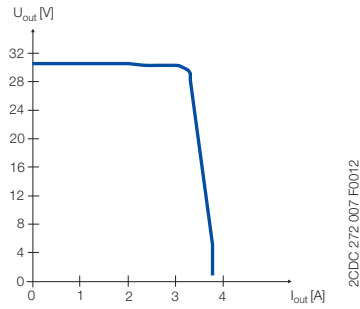

Output behaviour

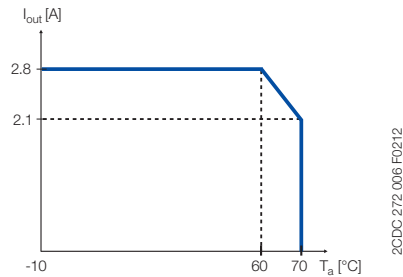

Temperaturkennlinie bei Bemessungslast

CP-ASI 4.0 DC/DC

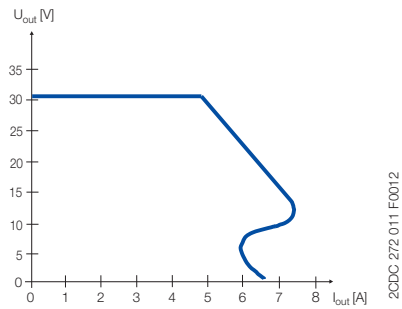

Output behaviour

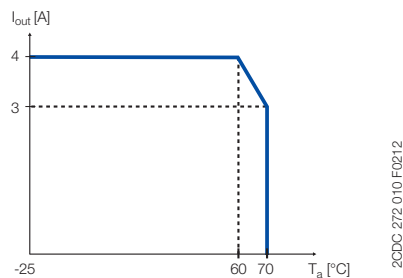

Characteristic curve of temperature at rated load

CP-ASI 4.0

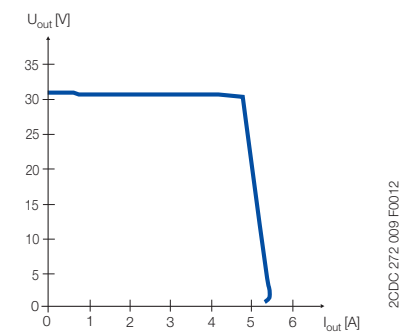

Output behaviour

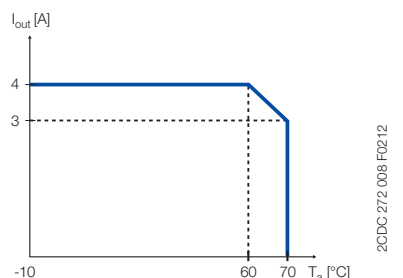

Characteristic curve of temperature at rated load

CP-ASI 8.0

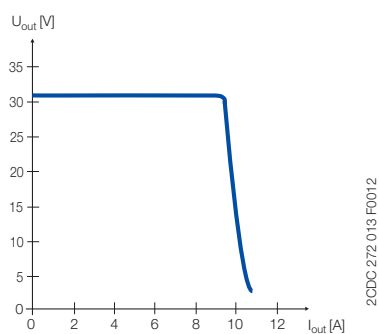

Output behaviour

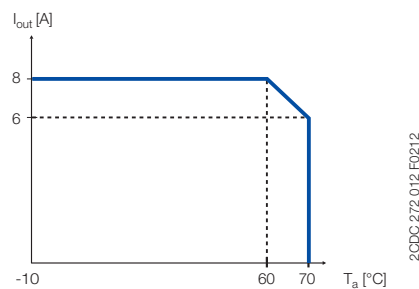

Characteristic curve of temperature at rated load

CP-ASI range

Dimensional drawings

Dimensions in mm/inch

CP-ASI 2.8

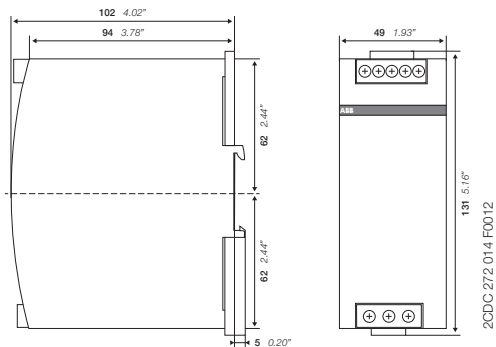

CP-ASI 4.0 DC/DC

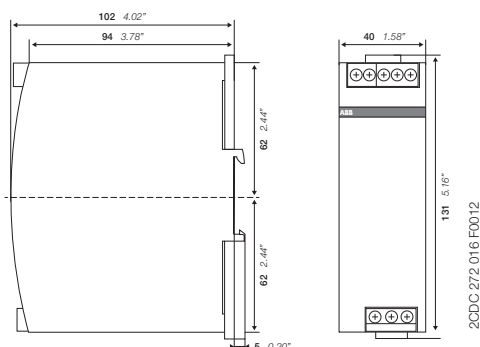

CP-ASI 4.0

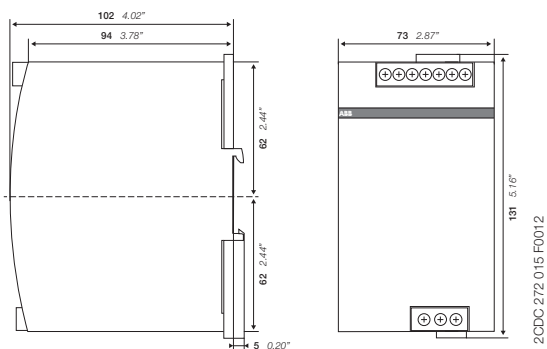

CP-ASI 8.0

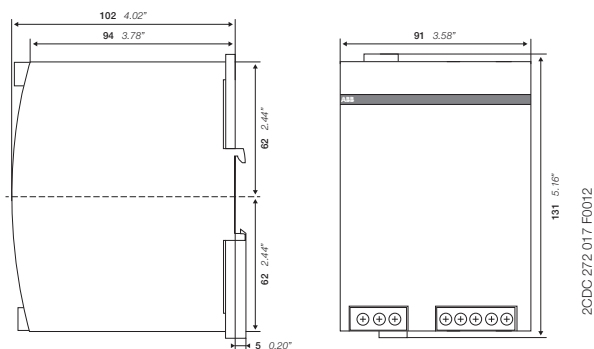

CP-B range Product group picture

3



CP-B range

Table of contents

CP-B	
Product group picture	3/65
Table of contents	3/66
Benefits and advantages	3/67
Ordering details	3/68
Technical data	3/69
Technical data, Technical diagrams	3/70
Dimensional drawings	3/71
Technical data	3/72

CP-B range

Benefits and advantages

Power supply systems have to be highly reliable in most areas of energy management and automation technology.

Often batteries are used for supporting the supply system in case of mains failures. Batteries have limited lifetimes depending on environmental parameters and have to be maintained regularly, which causes efforts and costs.

3

Using the latest ultra-capacitor technology, ABB offers an innovative and completely maintenance free new product for buffering the 24 V DC supply in case of interrupted mains on the primary side of the switch mode power supply.

The CP-B range is an ultra-capacitor buffer energy storage for power supply units which ensures a short term uninterrupted power supply system. In case of a power loss, the energy stored in the capacitor guarantees that the load is continually provided up to several hundred seconds depending on the load current.

Characteristics

- 3 buffer modules for buffering 24 V DC:
 - CP-B 24/3.0 (3 A / 1 kW^s¹⁾)
 - CP-B 24/10.0 (10 A / 10 kW^s¹⁾)
 - CP-B 24/20.0 (20 A / 8 kW^s¹⁾)
- CP-B 24/3.0 and CP-B 24/20.0 expandable with additional extension module(s) CP-B EXT.2 (2 kW^s¹⁾)
- LEDs for status indication
- Relay contacts for status messaging
- Very high backup times (e.g. with CP-B 24/10.0 up to 8 minutes at 1 A load current)
- Short charging times
- High efficiency, higher than 90%
- Wide temperature range
- DIN rail mountable, compact housing

Advantages in comparison to battery buffers:

- Maintenance free
- No deep discharge
- Temperature resistant
-  approval (UL508, CSA22.2 No 14)

¹⁾ internal energy buffer

		CP-B 24/3.0	CP-B 24/10.0	CP-B 24/20.0	CP-B EXT.2
Order code		1SVR427060R0300	1SVR427060R1000	1SVR427060R2000	1SVR427065R0000
Rated input voltage		24 V DC	24 V DC	24 V DC	–
Rated current		3 A DC	10 A DC	20 A DC	3 A DC
Energy storage (min.)		1.000 Ws	10.000 Ws	8.000 Ws	2.000 Ws
Typical charging time at load current	100 %	65 s	134 s	135 s	
	0 %	56 s	82 s	62 s	
Typical buffering time ¹⁾	100 %	13 s	38 s	15 s	
	50 %	28 s	76 s	30 s	
at load current	25 %	66 s	140 s	60 s	
	10 %	148 s	380 s	150 s	

$$^1) \text{ buffering time} \approx \frac{\text{energy storage} \times 0.9}{\text{current} \times \text{output voltage}}$$



1 Input terminals

SHUT-DOWN+, SHUT-DOWN-: Input signal terminals

INPUT OK, BUFFER STATUS, FAILURE: Signalling contact – terminals

L+_{IN}, L-_{IN}: Input voltage terminals

2 Indication of operational states

OPERATION: Buffer module in operation (standby or buffering)

INPUT OK: Input voltage applied

3 Output terminals

L+_{OUT}, L-_{OUT}, L-_{OUT}: Output voltage terminals

CP-B range

Ordering details



CP-B 24/3.0

2CDC 271 001 S0010



CP-B 24/10.0

2CDC 271 002 S0010



CP-B 24/20.0

2CDC 271 003 S0010

Description

Ultra capacitor based buffer units of the CP-B range offer highest reliability also in harsh environment. Due to the ultra-cap based technology the units are maintenance free, there will be no deep discharge and these products offer a very wide operational ambient temperature range.

CP-B range buffer units are an excellent solution to avoid voltage drops, for example in solar applications.

Ordering details

Rated input voltage	Rated current	Type	Order code	Price 1 pce	Weight (1 pce) kg (lb)
24 V DC	3 A DC	CP-B 24/3.0	1SVR427060R0300		0.55 (1.21)
	10 A DC	CP-B 24/10.0	1SVR427060R1000		2.10 (4.63)
	20 A DC	CP-B 24/20.0	1SVR427060R2000		2.20 (4.85)

Ordering details - Extension unit for CP-B 24/3.0 and CP-B 24/20.0

Rated voltage	Voltage range	Type	Order code	Price 1 pce	Weight (1 pce) kg (lb)
24 V DC	0-26.4 V DC	CP-B EXT.2	1SVR427065R0000		1.00 (2.20)

Example of application

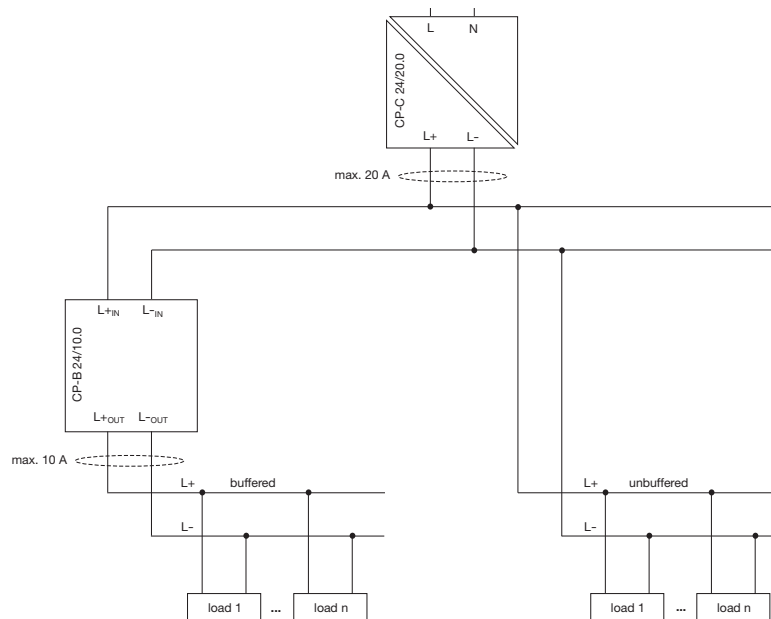

CP-B range

Technical data

Data at $T_a = 25\text{ °C}$ and rated values, unless otherwise indicated

Type		CP-B 24/3.0	CP-B 24/10.0	CP-B 24/20.0
Input circuit - Supply circuit				
		L+_{IN} L-_{IN}		
Rated input voltage U_{in}		24 V DC		
Input voltage range		23.7-26.4 V DC	23.9-27 V DC	23.4-27.4 V DC
Minimum charging potential		23.7 V DC	23.9 V DC	23.4 V DC
Rated input current		3 A DC	10 A DC	20 A DC
Inrush current limiting		50 A / 1 ms	35 A / 2 ms	35 A / 2 ms
Transient overvoltage protection		suppressor diode	varistor / suppressor diode	varistor / suppressor diode
Internal input fuse (apparatus protection, not accessible)		4 A slow acting	15 A (FK2)	30 A (FK2)
Internal fuse capacitors circuit (not accessible)			25 A (FK2)	
Kind of input	SHUT-DOWN	-	control input	control input
	rated voltage	-	24 V DC	24 V DC
	voltage range	-	6-45 V DC	6-45 V DC
Output circuit				
		L+_{OUT} L-_{OUT} L-_{OUT}		
Rated output power		69 W	240 W	480 W
Rated output voltage U_{out}		24 V DC		
Output voltage (buffer mode)		23.0 V DC	23.2 V DC	23.2 V DC
Tolerance of the output voltage		+2...-10 %		
Rated output current I	$T_a \leq 60\text{ °C}$	3 A DC	10 A DC	20 A DC
Peak output current (fully loaded capacitors required)	$T_a \leq 60\text{ °C}$	6 A DC (min. 1.5 s)	20 A DC (10 A power supply + 10 A CP-B, min. 1.5 s)	40 A DC (min. 1.5 s)
Control of limiting current		-	10.3 A DC $\pm 0.1A$	-
Shut-down if limiting current is exceeded		-	after 1.5 s	-
Short-circuit protection (only via external fuse)		-	no continuous short-circuit stability	-
Internal output fuse (not accessible)		-	15 A (FK2)	-
Required external fuse		3.15 A slow acting	10 A slow acting	25 A slow acting
Current limiting at output circuit		-	1.05...1.2 x I	-
Breaking capacity of output circuit	$\tau = 2.5\text{ ms}$	-	24 V DC, 10 A	-
Power failure buffering time ¹⁾		load-dependent, min. 13 s at 100 % load	load-dependent, min. 38 s at 100 % load	load-dependent, min. 15 s at 100 % load
Overload protection		thermal protection		
Kind of output	INPUT OK	n/o contact		
	BUFFER STATUS	-	n/o contact	
	FAILURE	-	c/o contact	
Contact material		Ag + Au-clad		
Minimum switching voltage / Minimum switching current		5 V DC / 1 mA		
Maximum switching voltage / Maximum switching current		50 V AC / 1.0 A, 30 V DC / 0.5 A		
Mechanical lifetime		5 x 10 ⁶ switching cycles		
Electrical lifetime		0.1 x 10 ⁶ switching cycles		
Maximum fuse rating to achieve short-circuit protection	n/o or n/c contact	1.0 A AC / 0.5 A DC		
General data				
Maximum internal power consumption		7 W	20 W	40 W
Power consumption with unloaded output		0.75 W	3 W	1.6 W
Energy storage (min.)		1000 Ws	10000 Ws	8000 Ws
Typical charging time at load current	100 %	65 s	134 s	135 s
	0 %	56 s	82 s	62 s
Typical buffering time at load current ¹⁾	100 %	13 s	38 s	15 s
	50 %	28 s	76 s	30 s
	25 %	66 s	140 s	60 s
	10 %	148 s	380 s	150 s
Efficiency		greater than 90 %		
Dimensions (W x H x D)	product dimensions	60 x 99 x 120 mm (2.36 x 3.90 x 4.72 in)	116 x 170 x 147 mm (4.57 x 6.69 x 5.79 in)	84 x 197 x 213 mm (3.31 x 7.76 x 8.39 in)
Weight	net weight	0.55 kg (1.21 lb)	2.1 kg (4.63 lb)	2.2 kg (4.85 lb)
Material	cover / housing shell	steel sheet powdered		
Mounting		DIN rail (IEC/EN 60715), snap-on mounting without any tool		
Mounting position		horizontal		
Minimum distance to other units	horizontal	not necessary		
	vertical	40 mm (1.58 in)		80 mm (3.15 in)
Pollution degree		2		
Degree of protection	housing / terminal	IP20		
Protection class (IEC/EN 61140)		III SELV / PELV (condition: power supply fulfills class III)		
Electrical connection - Input circuit / Output circuit				
		pull spring terminals	pull spring terminals	pluggable screw type terminals
Wire size	fine-strand with(out) wire end ferrule	0.08-1.0 mm ² (28-18 AWG)	0.08-1.5 mm ² (28-18 AWG)	0.2-4.0 mm ² (24-12 AWG)
	rigid	0.08-1.5 mm ² (28-16 AWG)	0.08-4.0 mm ² (28-16 AWG)	0.2-6.0 mm ² (24-10 AWG)

CP-B range

Technical data, Technical diagrams

Data at $T_a = 25\text{ °C}$ and rated values, unless otherwise indicated

Type	CP-B 24/3.0	CP-B 24/10.0	CP-B 24/20.0
Stripping length	6.0 mm (0.24 in)		7.0 mm (0.28 in)
Signalling circuit			
Wire size	fine-strand with(out) wire end ferrule		0.08-1.0 mm ² (28-18 AWG)
	rigid		0.08-1.5 mm ² (28-16 AWG)
Stripping length	6.0 mm (0.24 in)		7.0 mm (0.28 in)
Environmental data			
Ambient temperature	operation	-40...+60 °C	-20...+60 °C
	storage	-40...+60 °C	-20...+60 °C
Standards			
Product standard	EN 50178		
Low Voltage Directive	2006/95/EC		
EMC Directive	2004/108/EC		
RoHS Directive	2002/95/EC		
Electrical safety	EN 50178, EN 60950, UL 508		
Electromagnetic compatibility			
Interference immunity to	IEC/EN 61000-6-1, IEC/EN 61000-6-2		
electrostatic discharge	IEC/EN 61000-4-2	Level 3, 6 kV / 8 kV	
radiated, radio-frequency, electromagnetic field	IEC/EN 61000-4-3	Level 3, 10 V/m (27-1000 MHz) / Level 2, 3 V/m (1400-2700 MHz)	
electrical fast transient/burst	IEC/EN 61000-4-4	Level 3, 2(1) kV / 5 kHz	
surge	IEC/EN 61000-4-5	Level 1, 0.5 kV	
conducted disturbances, induced by radio-frequency fields	IEC/EN 61000-4-6	Level 3, 10 V (150 kHz-80 MHz)	
voltage dips, short interruptions and voltage variations	IEC/EN 61000-4-11	buffered by ultra-capacitors	
Interference emission	EN 61000-6-3, EN 61000-6-4		
high-frequency radiated	DIN EN 55011	B/C1	
high-frequency conducted	DIN EN 55011	B/C1	

$${}^1) \text{ buffering time} \approx \frac{\text{energy storage} \times 0.9}{\text{load current} \times \text{output voltage}}$$

„Approvals and marks“ on page 3/4.

Technical diagrams

Output curve at $T_u = 25\text{ °C}$

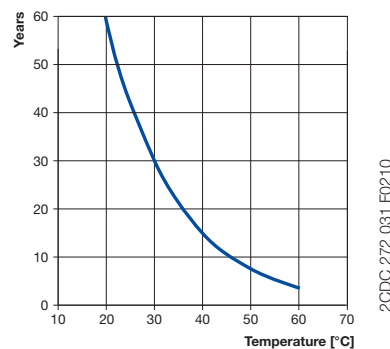
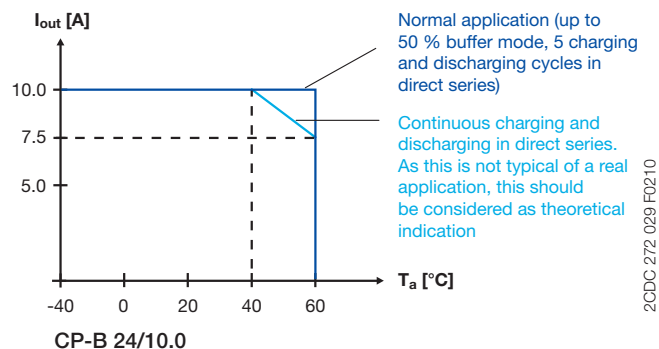
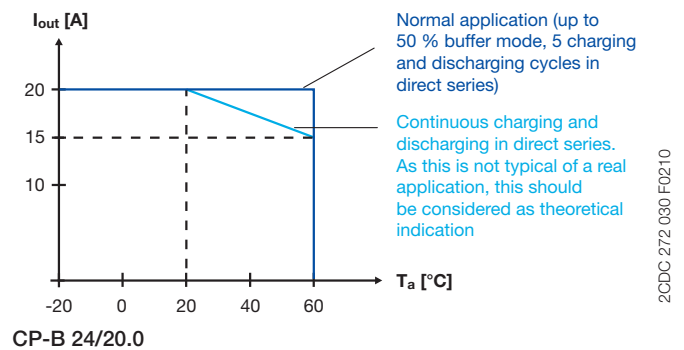
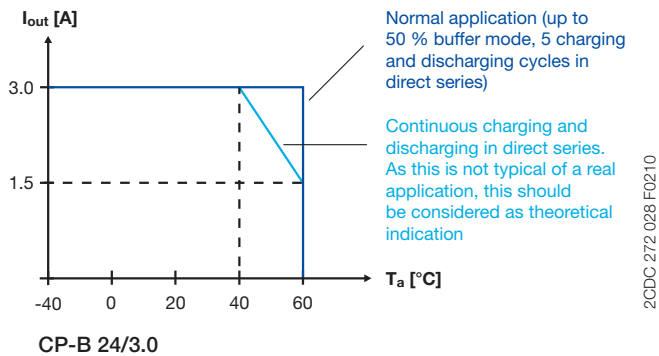

Characteristic curve of the temperature at rated load

Capacitor's life span over temperature

CP-B range Dimensional drawings

Dimensional drawings

dimensions in mm and inches

3

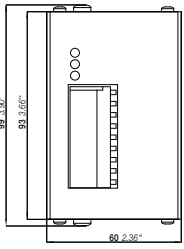

CP-B 24/3.0

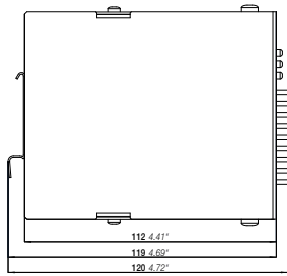

2CDC 272 037 F0010

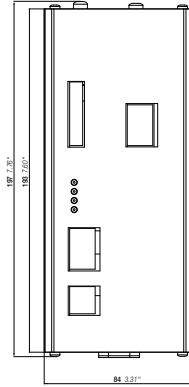

CP-B 24/20.0

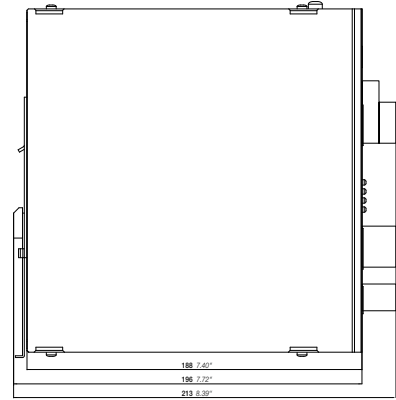

2CDC 272 039 F0010

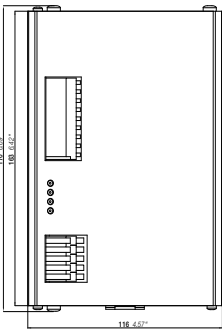

CP-B 24/10.0

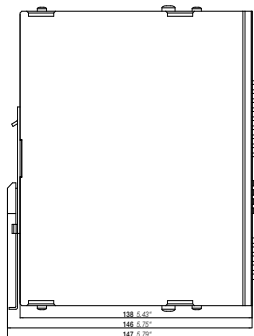

2CDC 272 038 F0010

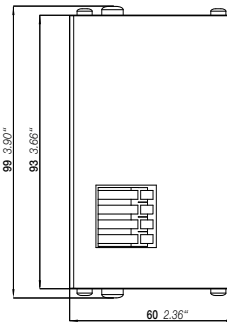

CP-B EXT.2

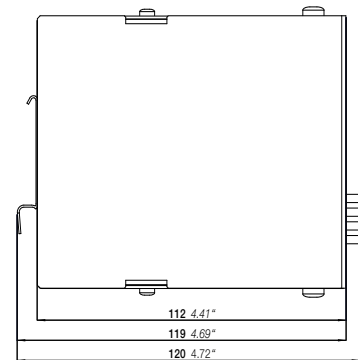

2CDC 272 036 F0010

CP-B range

Technical data

Data at $T_a = 25\text{ °C}$ and rated values, unless otherwise indicated

Type		CP-B EXT 2.0
Extension circuit		EXT+ EXT+ EXT- EXT-
Rated voltage		24 V DC
Voltage range		0-26.4 V DC
Rated current		3 A DC
Internal input fuse (apparatus protection, not accessible)		4 A slow acting (PTC)
Short-circuit protection		via internal 3 A fuse
Overload protection		only in combination with CP-B 24/3.0 or CP-B 24/20.0
Indication of operational states		status information and fault messages of the buffer module apply
General data		
Power consumption without load		0.5 W
Energy storage (min.)		2000 Ws
Dimensions (W x H x D)	product dimensions	60 x 99 x 120 mm (2.36 x 3.90 x 4.72 in)
	packaging dimensions	85 x 220 x 170 mm (3.35 x 8.66 x 6.69 in)
Weight	net weight	1.00 kg (0.20 lb)
Material	cover / housing shell	steel sheet powdered
Mounting		DIN rail (IEC/EN 60715), snap-on mounting without any tool
Mounting position		horizontal
Minimum distance to other units	horizontal	not necessary
	vertical	40 mm (1.58 in)
Pollution degree		2
Degree of protection	housing / terminal	IP20
Protection class (IEC/EN 61140)		III SELV / PELV (condition: power supply fulfills class III)
Electrical connection - Extension circuit		
Wire size	fine-strand with(out) wire end ferrule	0.08-1.0 mm ² (28-18 AWG)
	rigid	0.08-1.5 mm ² (28-16 AWG)
Stripping length		6.0 mm (0.24 in)
Signalling circuit		
Wire size	fine-strand with(out) wire end ferrule	0.08-1.0 mm ² (28-18 AWG)
	rigid	0.08-1.5 mm ² (28-16 AWG)
Stripping length		6.0 mm (0.24 in)
Environmental data		
Ambient temperature	operation	-40...+60 °C
	storage	-40...+60 °C
Vibration, sinusoidal	based on IEC/EN 60068-2-6	1.5 mm, 3-57.55 Hz; 2 g, 57.55-500 Hz, 10 cycles
Shock, half-sine	based on IEC/EN 60068-2-27	15 g, 11 ms, 3 axes, 6 faces, 3 times for each face
Standards		
Product standard		EN 50178
Low Voltage Directive		2006/95/EC
EMC Directive		2004/108/EC
RoHS Directive		2002/95/EC
Electrical safety		EN 50178, EN 60950, UL 508
Electromagnetic compatibility		
Interference immunity to		IEC/EN 61000-6-1, IEC/EN 61000-6-2
electrostatic discharge	IEC/EN 61000-4-2	Level 3, 6 kV / 8 kV
radiated, radio-frequency, electromagnetic field	IEC/EN 61000-4-3	Level 3, 10 V/m (27-1000 MHz) / Level 2, 3 V/m (1400-2700 MHz)
electrical fast transient/burst	IEC/EN 61000-4-4	Level 3, 2(1) kV / 5 kHz
surge	IEC/EN 61000-4-5	Level 1, 0.5 kV
conducted disturbances, induced by radio-frequency fields	IEC/EN 61000-4-6	Level 3, 10 V (150 kHz-80 MHz)
voltage dips, short interruptions and voltage variations	IEC/EN 61000-4-11	buffered by ultra-capacitors
Interference emission		EN 61000-6-3, EN 61000-6-4
high-frequency radiated	DIN EN 55011	B/C1
high-frequency conducted	DIN EN 55011	B/C1

„Approvals and marks“ on page 3/4.

Electronic protection devices EPD24

Product group picture

3



Electronic protection devices EPD24

Table of contents

Electronic protection devices EPD24	
Product group picture	3/73
Table of contents	3/74
Ordering details	3/75
Technical data	3/76
Technical information	3/78
Approvals, safety instructions	3/79
Installation guidelines	3/80

Electronic protection devices EPD24

Ordering details

3



2CDC 051 001 S9010

EPD24-TB-101-3A

The protection devices EPD24 extend the ABB product range of Modular DIN rail components by electronic overcurrent protection modules for selective protection of 24V DC load circuits.

This protection is achieved by a combination of active electronic current limitation in the case of a short circuit and an overload deactivation from $1.1 \times I_n$ upwards.

If a fault occurs in a load circuit, the protection device EPD24 will detect this rapidly and reliably, disable the power output transistor and hence interrupt the current flow in the defective circuit. The maximum possible overcurrent is always limited to 1.3...1.8 times the selected rated current. An activation of capacitive loads up to 20,000 μF is possible, deactivation only occurring in the case of overloads or short circuits. Selective deactivation of the defective current circuit means undefined error states and a complete system stop are prevented.

Features

- Selective load protection, one electronic tripping characteristic.
- Active current limitation for safe connection of capacitive loads up to 20,000 μF and on overload/short circuit.
- Current ratings 0.5 A...12 A.
- Reliable overload disconnection with $1.1 \times I_n$
- Manual ON/OFF button
- Clear status and failure indication through LED and integrated auxiliary contact.
- Integral fail-safe element adjusted to current rating.
- Width per unit only 12.5 mm.
- Rail mounting
- Ease of wiring through busbar LINE+ and 0 V as well as signal bars.
- UL- and CSA-approvals allow international use of the devices.

Ordering details

Rated current I_n A	bbn 40 16779 EAN	Type	Order code	Price	Pkg qty	Weight (1 pce) kg (lb)
0.5	829960	EPD24-TB-101-0.5A	2CDE601101R2905		4	0.065 (1.433)
1	829984	EPD24-TB-101-1A	2CDE601101R2001		4	0.065 (1.433)
2	830003	EPD24-TB-101-2A	2CDE601101R2002		4	0.065 (1.433)
3	830027	EPD24-TB-101-3A	2CDE601101R2003		4	0.065 (1.433)
4	830041	EPD24-TB-101-4A	2CDE601101R2004		4	0.065 (1.433)
6	830065	EPD24-TB-101-6A	2CDE601101R2006		4	0.065 (1.433)
8	830089	EPD24-TB-101-8A	2CDE601101R2008		4	0.065 (1.433)
10	830102	EPD24-TB-101-10A	2CDE601101R2010		4	0.065 (1.433)
12	830126	EPD24-TB-101-12A	2CDE601101R2012		4	0.065 (1.433)

Ordering details

Description	bbn 40 16779 EAN	Type	Order code	Price	Pkg qty	Weight (1 pce) kg (lb)
Busbars for LINE+ and 0 V, grey insulation, length 500 mm ¹⁾	830140	EPD-BB500	2CDE605100R0500		10	0.2 (0.441)
Signal Bars for aux. contacts, grey insulation, length 21 mm	830164	EPD-SB21	2CDE605200R0021		10	0.4 (0.882)

¹⁾ Max. load with one line entry $I_{max} = 50$ A (recommended: mid line entry)
Max. load with two line entries $I_{max} = 63$ A

Electronic protection devices EPD24

Technical data

Wiring diagramm

EPD24-TB-101

without signal input
with signal output F
(Single signal, N/O)

Operating condition: 13-14 closed
Fault condition: 13-14 open

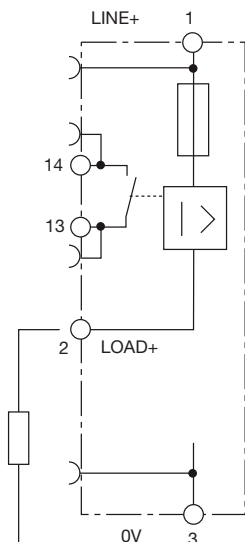

Operating data

Operating voltage U_B :	24 V DC (18...32 V)
Current rating I_N :	fixed current ratings: 0.5, 1, 2, 3, 4, 6, 8, 10, 12 A
Closed current I_V :	ON condition: typically 20...30 mA depending on signal output
Status indication by means of:	<ul style="list-style-type: none"> – multicolour LED: <ul style="list-style-type: none"> Green: <ul style="list-style-type: none"> – unit is ON – load circuit / Power-MOSFET is switched on Orange: <ul style="list-style-type: none"> – in the event of overload or short circuit until electronic disconnection Red: <ul style="list-style-type: none"> – unit electronically disconnected – load circuit/Power-MOSFET OFF – undervoltage ($U_B < 8$ V) – after switch-on till the end of the delay period OFF: <ul style="list-style-type: none"> – manually switched off – or device is dead
	– potential-free auxiliary contact F
	– ON/OFF/ condition of switch

Load circuit

Load output	Power-MOSFET switching output (high side switch)
Overload disconnection	typically $1.1 \times I_N$ ($1.05...1.35 \times I_N$)
Short-circuit current I_k	active current limitation
Trip time	see time/current characteristics
For electronic disconnection	typically 3 s at $I_{Load} > 1.1 \times I_N$ typically 100 ms...3 s at $I_{Load} > 1.8 \times I_N$ (or $1.5 \times I_N / 1.3 \times I_N$)
Temperature disconnection	internal temperature monitoring with electronic disconnection
Low voltage monitoring load output	with hysteresis, no reset required: load »OFF« at $U_B < 8$ V
Starting delay t_{start}	typically 0.5 sec after every switch-on and after applying U_B
Disconnection of load circuit	electronic disconnection
Free-wheeling circuit	suitable external free-wheeling circuit to be used with inductive load

Several load outputs must not be connected in parallel

Signal output

Electrical data	potential-free auxiliary contact max. 30 V DC/0.5 A, min. 10 V DC/10 mA
ON condition LED green	voltage U_B applied, switch is in ON position no overload, no short circuit
OFF condition LED off	– device switched off (switch is in OFF position) – no voltage U_B applied
Fault condition LED orange	overload condition $> 1.1 \times I_N$ up to electronic disconnection
Fault condition LED red	– electronic disconnection upon overload or short circuit – Device switched off with control signal (switch is in ON position)
Aux. contact	single signal, make contact
Fault	contact open, terminal 13-14 signal output fault conditions – no operating voltage U_B – ON/OFF switch is in OFF position – red LED lighted (electronic disconnection)

Electronic protection devices EPD24

Technical data

3

General data

Fail-Safe element	backup fuse for EPD24 not required because of the integral redundant fail-safe element
Housing material	moulded
Mounting	symmetrical rail to EN 50022-35x7.5
Ambient temperature	0...+50 °C (without condensation, see EN 60204-1)
Storage temperature	-20...+70 °C
Humidity	96 hrs/95 % RH/40 °C to IEC 60068-2-78, test Cab. climate class 3K3 to EN 60721
Vibration	3 g, test to IEC 60068-2-6 test Fc
Degree of protection	housing: IP20 DIN 40050 terminals: IP20 DIN 40050
EMC	emission: EN 61000-6-3
(EMC directive, CE logo)	susceptibility: EN 61000-6-2
Isolations coordination (IEC 60934)	0.5 kV/pollution degree 2 reinforced insulation in operating area
Dielectric strength	max. 32 V DC (load circuit)
Isolation resistance (OFF condition)	n/a, only electronic disconnection
Approvals/Declarations of conformity	UL 2367 Solid State Overcurrent Protectors UL 1604, (class I, division 2, groups A, B, C, D) UL 508 CSA C22.2 No. 213 (class I, division 2) CSA C22.2 No. 142 CE logo
Dimensions (B x H x T)	12.5 x 80 x 83 mm
Weight	approx. 65 g

Terminals

Line+/LOAD+/0V

Screw terminals	M4
Max. cable cross section flexible with wire end ferrule w/wo plastic sleeve	0.5 – 10 mm ²
Multi-lead connection (2 identical cables) rigid/flexible	0.5 – 4 mm ²
Flexible with wire end ferrule without plastic sleeve	0.5 – 2.5 mm ²
Flexible with TWIN wire end ferrule with plastic sleeve	0.5 – 6 mm ²
Wire stripping length	10 mm
Tightening torque (EN 60934)	1.5 – 1.8 Nm

Terminals

aux. contacts

Screw terminals	M3
Max. cable cross section flexible with wire end ferrule w/wo plastic sleeve	0.25 - 2.5 mm ²
Wire stripping length	8 mm
Tightening torque (EN 60934)	0.5 Nm

Table 1: voltage drop, current limitation, max. load current

current rating I_N	typically voltage drop U_{ON} at I_N	active current limitation (typically)	max. load current at 100 % ON duty	
			$T_{ambient} = 40\text{ °C}$	$T_{ambient} = 40\text{ °C}$
0.5 A	70 mV	$1.8 \times I_N$	0.5 A	0.5 A
1 A	80 mV	$1.8 \times I_N$	1 A	1 A
2 A	130 mV	$1.8 \times I_N$	2 A	2 A
3 A	80 mV	$1.8 \times I_N$	3 A	3 A
4 A	100 mV	$1.8 \times I_N$	4 A	4 A
6 A	130 mV	$1.8 \times I_N$	6 A	5 A
8 A	120 mV	$1.5 \times I_N$	8 A	7 A
10 A	150 mV	$1.5 \times I_N$	10 A	9 A
12 A	180 mV	$1.3 \times I_N$	12 A	10.8 A

Attention: when mounted side-by-side without convection the EPD24 should not carry more than 80 % of its rated load with 100 % ON duty due to thermal effects.

Electronic protection devices EPD24

Technical information

Time/Current characteristic curve ($T_{\text{ambient}} = 25\text{ °C}$)

- The trip time is typically 3 s in the range between $1.1 \times I_N$ and $1.8 \times I_N$ ¹⁾.
- Electronic current limitation occurs at typically $1.8 \times I_N$ ¹⁾ which means that under all overload conditions (independent of the power supply and the resistance of the load circuit) the max. overload before disconnection will not exceed $1.8 \times I_N$ times the current rating. Trip time is between 100 ms and 3 sec (depending on overload or at short circuit).
- Without this current limitation a considerably higher overload current would flow in the event of an overload or short circuit.

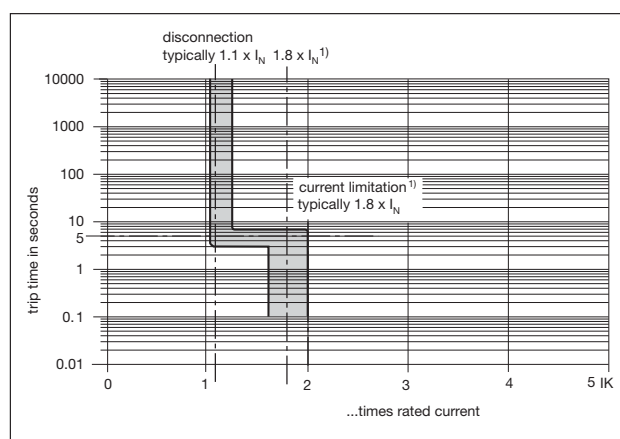

¹⁾ Current limitation typically $1.8 \times I_N$ at $I_N = 0.5\text{ A}..6\text{ A}$
 Current limitation typically $1.5 \times I_N$ at $I_N = 8\text{ A}$ or 10 A
 Current limitation typically $1.3 \times I_N$ at $I_N = 12\text{ A}$

Maximum cable lengths

EPD24 reliably trips from $0\ \Omega$ up to max. circuit resistance R_{max} .

Calculation of R_{max}

Selected rating I_N (A)	3	6
Operating voltage U_S (V DC) (= 80 % of 24 V) ²⁾	19.2	19.2
Trip current $I_{\text{ab}} = 1.25 \times I_N$ (A) (EPD24 trips after 3 s)	3.75	7.50
$R_{\text{max}} (\Omega) = (U_S / I_{\text{ab}}) - 0.050$	5.07	2.51

²⁾ Voltage drop of EPD24 and tolerance of trip point (typically $1.1 \times I_N = 1.05 \dots 1.35 \times I_N$) have been taken into account

Selection table for the incoming cable lengths with different cable cross-sections

Cable cross section A (mm ²)	0.14	0.25	0.34	0.5	0.75	1.00	1.50
Cable length L (m) (= single length)	cable resistance (Ω) = $(\rho_0 \times 2 \times L) / A$ ³⁾						
5	1.27	0.71	0.52	0.36	0.24	0.18	0.12
10	2.54	1.42	1.05	0.71	0.47	0.36	0.24
15	3.81	2.14	1.57	1.07	0.71	0.53	0.36
20	5.09	2.85	2.09	1.42	0.95	0.71	0.47
25	6.36	3.56	2.62	1.78	1.19	0.89	0.59
30	7.63	4.27	3.14	2.14	1.42	1.07	0.71
35	8.90	4.98	3.66	2.49	1.66	1.25	0.83
40	10.17	5.70	4.19	2.85	1.90	1.42	0.95
45	11.44	6.41	4.71	3.20	2.14	1.60	1.07
50	12.71	7.12	5.24	3.56	2.37	1.78	1.19
75	19.07	10.68	7.85	5.34	3.56	2.67	1.78
100	25.34	14.24	10.47	7.12	4.75	3.56	2.37
125	31.79	17.80	13.09	8.90	5.93	4.45	2.97
150	38.14	21.36	15.71	10.68	7.12	5.34	3.56
175	44.50	24.92	18.32	12.46	8.31	6.23	4.15
200	50.86	28.48	20.94	14.24	9.49	7.12	4.75
225	57.21	32.04	23.56	16.02	10.68	8.01	5.34
250	63.57	35.60	26.18	17.80	11.87	8.90	5.93

³⁾ Resistivity of copper $\rho_0 = 0.0178 (\Omega \times \text{mm}^2) / \text{m}$

Example 1: max. length for 1.5 mm² and 3 A: **214 m**

Example 2: max. length for 1.5 mm² and 6 A: **106 m**

Example 3: mixed wiring: (Control cabinet --- sensor/actuator level)

$R_1 = 40\text{ m}$ for 1.5 mm² and $R_2 = 5\text{ m}$ for 0.25 mm²:

$R_1 = 0.95\ \Omega$, $R_2 = 0.71\ \Omega$, **total ($R_1 + R_2$) = 1.66 Ω**

Electronic protection devices EPD24

Approvals, Safety instructions

Please note

The user must ensure that the cable cross sections of the relevant load circuit are suitable for the current rating of the EPD24 used. Automatic start-up of machinery after shut down must be prevented (Machinery Directive 98/37/EG and EN 60204-1). In the event of a short circuit or overload the load circuit will be disconnected electronically by the EPD24.

Information on UL approvals/CSA approvals

3



UL1604
UL File # E 339238



CSA C22.2 No. 213 (Class I, Division 2)
CSA File # 2305929

Operating Temperature Code T5

- This equipment is suitable for use in Class I, Division 2, Groups A, B, C and D or non-hazardous locations only

WARNING:

- Exposure to some chemicals may degrade the sealing properties of materials used in the following device: relay

Sealant Material:

Generic Name: Modified diglycidyl ether of bisphenol A

Supplier: Fine Polymers Corporation

Type: Epi Fine 4616L-160PK

Casing Material:

Generic Name: Liquid Crystal Polymer

Supplier: Sumitomo Chemical

Type: E4008, E4009, or E6008

RECOMMENDATION:

- Periodically inspect the device named above for any degradation of properties and replace if degradation is found

WARNING – EXPLOSION HAZARD:

- Do not disconnect equipment unless power has been removed or the area is known to be non-hazardous
- Substitution of any components may impair suitability for Class I, Division 2

UL2367



Non-hazardous use - UL File # E 339236

UL 508



Non-hazardous use - UL File # E 149922

CSA C22.2 No. 14



CSA C22.2 No. 142 - CSA File # E 2305929

Class 2

Meets requirement for Class 2 current limitation (EPD24 ... -0,5 A/1 A/2 A/3 A)

Electronic protection devices EPD24

Installation guidelines

The EPD24 features an integral power distribution system.

The following wiring modes are possible with various pluggable current and signal busbars:

- LINE+ (24 V DC)
- 0 V
- **Caution:** The electronic devices EPD24 require a 0 V connection
- Auxiliary contacts

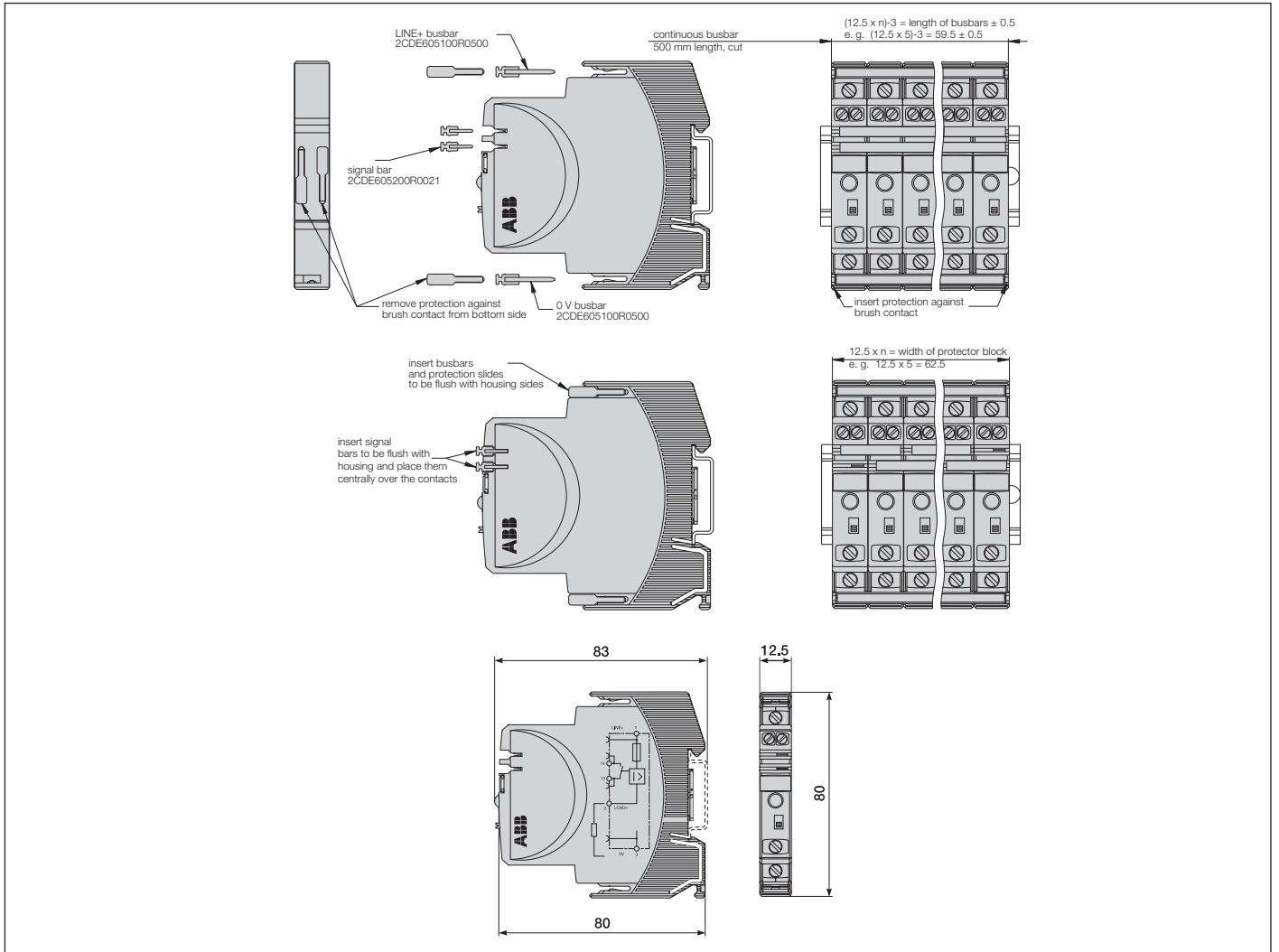

Mounting procedure

Before wiring insert busbars into protector block. A maximum of 10 connection cycles are permissible using connecting busbars.

Recommendation

After 10 units the busbars should be interrupted and receive a new entry live.

Table of length for busbars

(Order code 2CDE605100R0500)

No. of units	2	3	4	5	6	7	8	9	10
Length of busbar (mm) ± 0.5 mm	22	34.5	47	59.5	72	84.5	97	109.5	122